

Instruction Sheet for P613-K (12 or 24 VDC)



Part List- Description

Cable Pivot
Wire Core
Cable Bulkhead Fitting
Cable Bracket
Cable Assembly
Jam Nut UNF 3/8-24
Aluminum Adjustment Nut 1.00 Inch Hex
* Control Module (S500-A60)
* Only sold with kit: - K1, K3, K5, K8, K9

Control Module S500-A60 Product Specifications:

Voltage Nominal	12 Volts	24 Volts
Voltage Input Min. Max. Range:	8.5-32 (See Note 1)	8.5-32 (See Note 1)
Max Load Current:	80	40
Max Power Load:	1000 Watts	1000 Watts
Recycle Time:	.25 Sec. (See Note 3)	.25 Sec. (See Note 3)
Auxiliary input current requirement:	Less than 50 milliamp	Less than 50 milliamp
Operating Ambient Temp:	-30°C + 80°C	-30°C + 80°C
Actuation Time:	.5 Sec.	.5Sec.
Transient Voltage Protection:	Integral 5000 Watt Peak Pulse Power TVS	
Insertion Loss::	1.0 volt w/75 Amp Load 0.69 Volt w/50Amp load	
Maximum Cycle Rate:	6 Cycles/Minute for 1 minute max. duration (See Note 2)	
Reverse Polarity Protection:	Withstands brief reverse polarity of battery inputs if properly fused.	

Notes:

1. Minimum voltage required to assure full pull-in time is achieved.
2. Maximum cycle rates specification is provided as a figure of merit only. It is intended to provide some idea of what the module can withstand in a burst of rapid cycling with short time intervals will result in damage to the solenoid or module.
3. Minimum time voltage must be removed from the Aux input in order for the pull in timer to reset for full 0.5 second pull in.

****** Consult Trombetta if high vibration is anticipated******

No implied warranty is intended. All information is subject to change without notice.

Instruction Sheet for P613-K (12 or 24 VDC)

Industrial Work Solenoid Assembly Specifications:

Specifications:	12 Volt Solenoid	24 Volt Solenoid
Rated Voltage:	12VDC	24VDC
Pull-In Current:	70.5 Amps	36.4 Amps
Hold-In Current:	0.9 Amps	0.5 Amps
Pull-In Force (at 68F [20C])	20 lb.	20 lb.
Hold-In Force (at 68F [20C])	40 lb.	40 lb.
Maximum Ambient Temperature:	257F (125°C)	257F (125°C)
Maximum Coil Temperature	380F(193°C)	380F(193°C)
Maximum Cycle Rate	6/min. (See note 2)	6/min. (See note 2)

****** SAFETY FIRST ******

Trombetta has made every effort to provide you with a safe throttle kit, but wishes to point out information on safe installation and operation.

WARNING: To avoid control module damage, always disconnect the module when you jump-start the vehicle with voltages that exceed 32 VDC.

CAUTION: To avoid eye or face injury, eye or face protection must be worn when installing this device.

IMPROPER INSTALLATION OF CABLE PIVOT CAN RESULT IN PREMATURE WIRE CABLE FAILURE.

***** CONSULT THE DIAGRAM BELOW FOR PROPER INSTALLATION *****

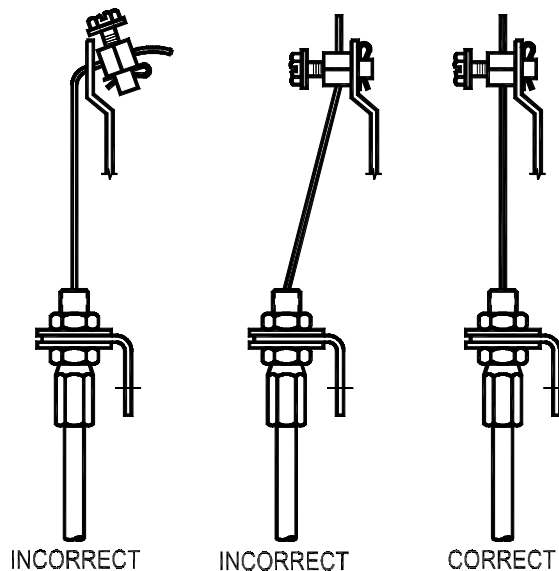

Instruction Sheet for P613-K (12 or 24 VDC)

Installing Your Throttle Control Kit:

Location

- Mount the industrial work solenoid off the engine but within 46 inches (116.8 cm) of the throttle lever, to avoid engine vibration and high temperature components (more than 257°F [125°C]).
- Mount Control Module (S500-A60) out of the engine compartment if possible. If not possible, mount the module as far away from high temperature components as possible. Maximum temperature range is 185F (85°C).
- Route the flexible cable away from high temperature (220°F [105°C]) components such as exhaust manifolds.
- Avoid sharp bends in flexible cable. Bends should form a smooth arc (360 maximum) with a radius of 5 inches (12.7 cm) minimum.

Mounting Procedures:

Use the following procedure to mount your throttle controller:

1. Mount the solenoid and control module according to the recommendations on the "location" instructions.
2. Electrically connect the solenoid to the control module and power source according to the wiring diagram.
3. Mount the cable bracket (1) and fasten the cable sheath to the bracket using the collar nut so the sheath does not turn during idle adjustment.

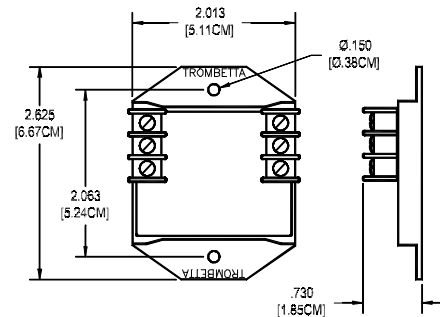
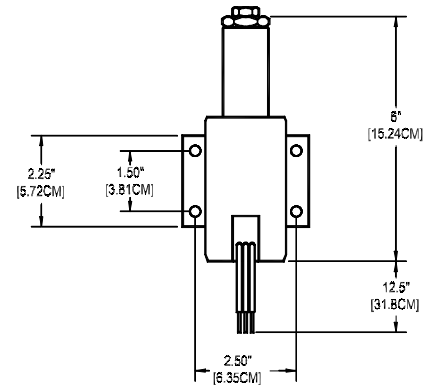
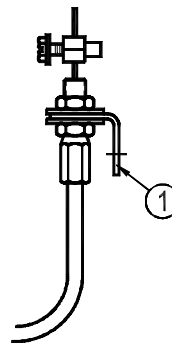

Controlling the Throttle Control Kit:

The throttle kit can be controlled remotely by applying a low current 12 or 24 VDC signal to the module "AUX" terminal. Examples of activating signals are the air compressor pressure switch or air conditioning switching circuits.

Use the following table to determine all wire lengths, and gages, except "AUX" terminal:

Note: The wire size and length to "AUX" terminal of the control module is not critical because of low current; 16-18 gage wire may be used.

Maximum Lead Length – In Feet*							
System Voltage	Wire Gage						
	18 AWG	16 AWG	14 AWG	12 AWG	10 AWG	8 AWG	6 AWG
12 VDC	2.5 ft.	4 ft.	6 ft.	10 ft.	16 ft.	25 ft.	40 ft.
24 VDC	10 ft.	16 ft.	25 ft.	40 ft.	64 ft.	100 ft.	160 ft.

* Total of "+BAT" and "-BAT" and "WHITE" and "Black" wire lengths.

Instruction Sheet for P613-K (12 or 24 VDC)

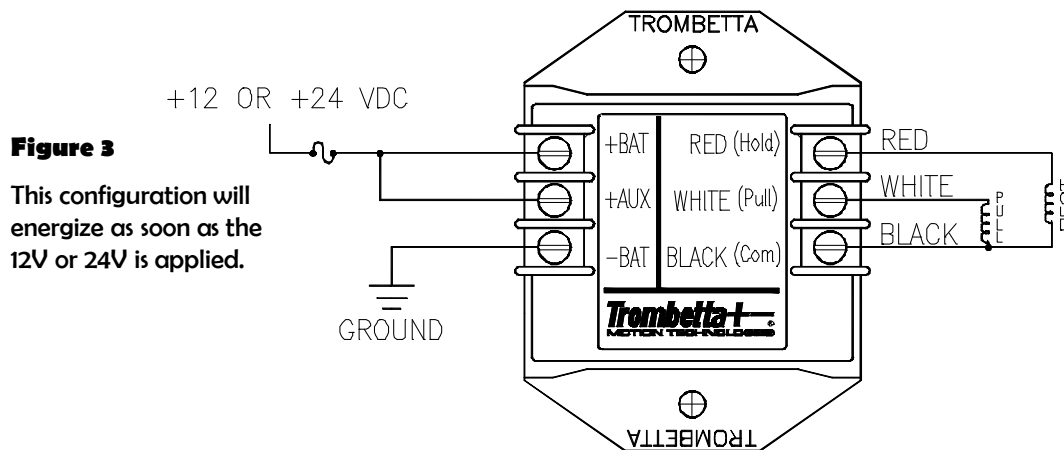
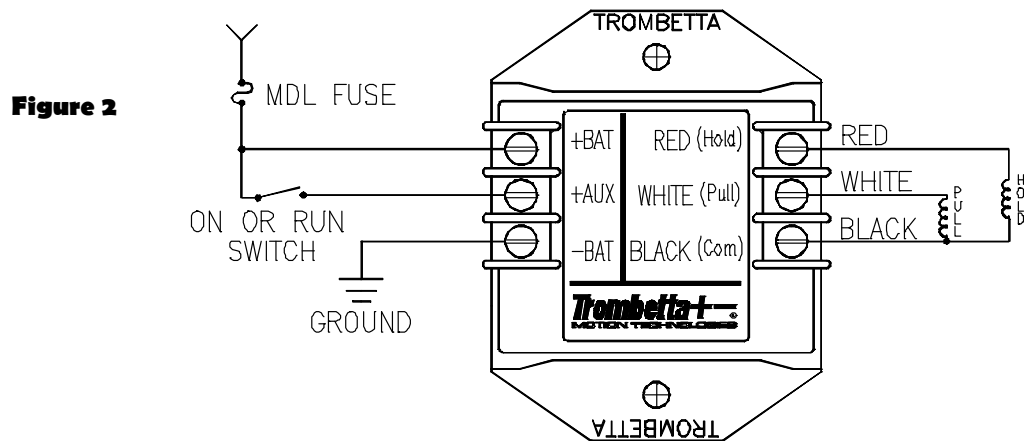
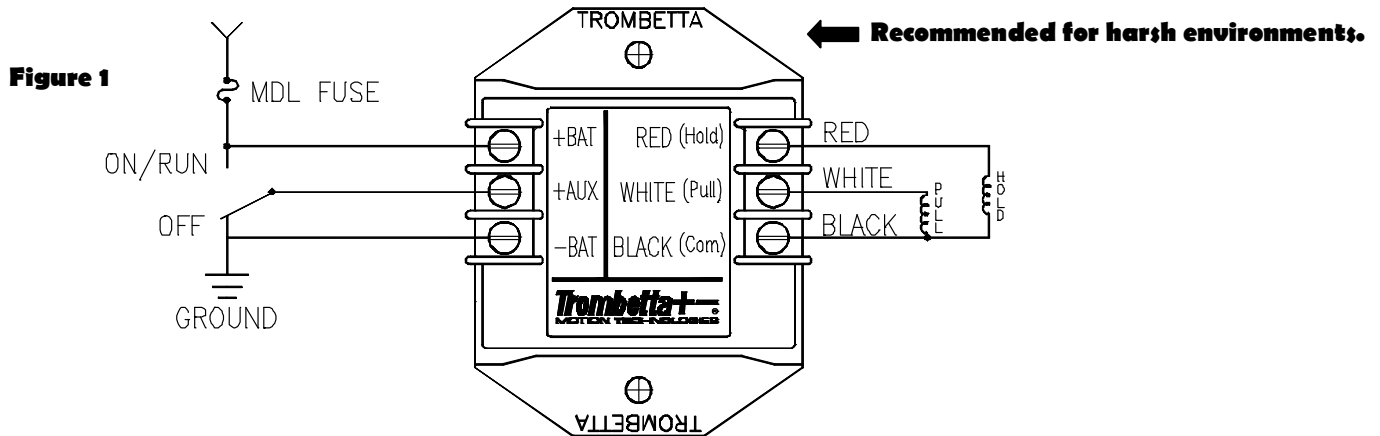

Note: When using a S500-A60 module all of the solenoid connections must connect to the module as shown. Do not connect any of the solenoid leads to another ground point in the system.

Note: Wire size must be sufficient to handle the current draw of the solenoid.

Note: 12VDC 15 Amp MDL slow blow fuse maximum recommended.

Note: 24VDC 7½ MDL slow blow fuse maximum recommended.

Instruction Sheet for P613-K (12 or 24 VDC)

Set Normal Engine Idle Speed

Use the following procedure to set the “normal” engine idle speed with the solenoid de-energized:

1. With the engine “off” attach the cable pivot assembly (1) to the throttle lever.
Note: DO NOT tighten the wire core pivot setscrew (1A). The wire core (2) must be free to move through the pivot until step
2. Insert the wire core (2) into the wire core pivot (1)
3. If the cable adjuster is not fully retracted into the solenoid, loosen the jam nut (6) and turn the aluminum adjustment nut (7) counterclockwise until the cable adjustment nut (7) is flush with the solenoid (8).
4. With all connections made to the throttle control systems, apply 12VDC or 24VDC to “AUX” terminal of the control module. Make sure the wire core (2) is free to move through the cable pivot (1) without restriction.
5. Adjust “normal” engine idle speed using the “standard method” required for your engine.
6. Eliminate the slack in the cable (2).
7. Tighten the cable pivot setscrew (1A).

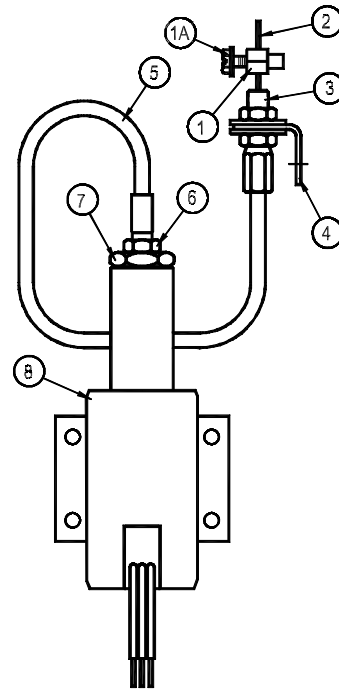

Set High Idle Speed

Use the following procedure to set the “high” engine idle speed with the solenoid activated:

1. Set the “normal” engine idle speed per the previous procedure.
2. With the engine running, apply 12 VDC or 24VDC to the “AUX” terminal of the control module.
3. Make sure the jam nut (6) is loose and turn the aluminum adjustment nut (7) clockwise until the high engine idle speed is reached.
4. Tighten the jam nut (6).
5. Check the throttle speed controller operation rechecking the “normal” engine idle speed with the solenoid deactivated and high engine idle speed with the solenoid activated. If necessary, repeat the “normal” idle speed and high idle speed adjustments.

Note: Do not leave the aluminum adjustment nut (7) tight against the solenoid body since this does not allow the cable (5) to float.

Instruction Sheet for P613-K (12 or 24 VDC)

System Operation

The P613-K Throttle Control Kit consists of a 3-wire dual coil solenoid, solid state control module, and stainless steel sheathed pull cable. The sheathed pull cable allows the solenoid to be mounted away from hostile environments, such as engine vibration and high temperature.

The throttle industrial work solenoid can be activated automatically for “on-demand” operation to bring the idle speed to a preset high idle position.

The control module allows the solenoid to operate as a continuous duty device. When the module is wired as recommended, (in figure 1 or 2) applying 12 or 24 VDC to the “+AUX” terminal will result in power being applied to the pull-in and hold coils of the solenoid. After 0.5 to 0.75 seconds, voltage to the solenoid is reduced to a level suitable for continuous operation of both the pull-in and hold coils. Suitable power will continue to be applied to the solenoid until the control signal is removed from the “+AUX” terminal.

Control Module Voltage Measurements	
Terminal Designation	Voltage
-BAT	Chassis Ground
+BAT	12 or 24 VDC at all times
+AUX	12 or 24 VDC required to activate the solenoid
RED (HOLD)	12 or 24 VDC after 0.5 to 0.75 seconds signal at “AUX” terminal then switches to PWM mode.
WHITE (PULL)	
BLACK (COM)	Common for solenoid

Troubleshooting Hints

If the solenoid will not engage, check the following:

1. Check the stranded pull cable for damage (e.g., melted or crimped sheath).
2. Check the stranded pull cable for binding.
3. Check system voltage at the +BAT and +AUX terminals.
4. Check module terminals for proper voltage and operation. If the module does not meet these specifications, replace it.
5. Check solenoid resistance (remove wires from module). If resistance is not within specifications listed below, replace the solenoid.
6. Make sure you have the recommended wire length and gage (refer to wire gage chart pg. 3).
7. Be sure cable is not bent beyond guidelines.
8. Check for proper adjustments.
9. Contact the factory if you are unable to resolve the problem.

12 VDC System	24 VDC System
* 0.17 ohms White to Black wire	* 0.66 White to Black wire
13.6 ohms Red to Black wire	50 ohms Red to Black wire
* Resistance below 1 ohm can not be accurately measured with a conventional ohm meter, a milli ohm meter is required.	

Instruction Sheet for P613-K (12 or 24 VDC)

Trombetta Pull Cable Shortening Instructions

Use the following procedures to shorten pull cables supplied with Trombetta products

IMPORTANT: DO NOT cut wire core (2) until step # 11! Remove wire core (2) from cable sheath (5) before cutting the sheathing.

1. Remove the cable assembly (1-7) from the solenoid body (8) by loosening the jam nut (6) and turning the large aluminum adjusting nut (7) "clockwise".

Note: The solenoid "plunger" located inside the solenoid body can be removed at this point. Do not damage or contaminate the plunger while it is out of the solenoid body (8). Be sure to keep the inside of the solenoid body (8) "clean" while the plunger is removed.

2. Remove the wire core (2) from the cable sheath (5)
3. Lightly fixture the cable sheath (5) in a vise or other suitable holding device.

Note: Over tightening the vise may deform the cable sheath (5) and cause the wire core (2) to bind!

CAUTION: Safety Goggles must be worn before proceeding!

4. Use an abrasive "cut-off wheel" (eg. A Dremel tool and Dremel abrasive disk), to cut the cable sheath (5) to the desired length. Deburr and clean the "cut end" of the sheath (5).
5. Mark the cable sheath (5) 1" from the end with a wrap of masking tape (see Fig. C).
6. If the threaded-on bulkhead connector is to be reused, remove it from the cut-off piece of cable sheathing by unthreading it in a counter-clockwise direction. Wipe the connector clean and reuse it for step #8.
7. Wipe the wire core (2) clean and then re-insert this core (2) through the cable sheath (5).

Note: Make sure the wire core (2) moves "freely" inside the cable sheath (5). If it does not, discard the whole cable assembly and replace.

8. Turn the "cable bulkhead fitting" (see fig. A) onto the sheathing (5). Torque to maximum 8 pound-inches. At this point, the fitting should be approximately $\frac{1}{4}$ " or less from the tape mark on the sheath.

CAUTION: Cable bulkhead fitting must engage at least $\frac{3}{4}$ " of the cable sheath to be properly attached. Over tightening the fit may strip the threads.

9. Re-install the cable assembly.
10. Using the "throttle solenoid" setting instructions, proceed with setting the throttle solenoids.
11. After the throttle solenoid is set and connections are tightened, cut the excess wire core approximately "one" inch beyond the cable pivot (1).

