

# EnerGenius® IQ

Filtered Charger/Rectifier & Battery Check System  
by SENS



## Installation & Operation Manual

### IQ Case Size Q2

12V/75-150A

24V/75-150A

48V/75-100A

120V/35-50A

240V/16-25A

---

SENS Part Number:	101308-2
Document Revision:	M
DCN Number:	106366
Date:	August 30, 2013



*Our energy means business*

STORED ENERGY SYSTEMS

1840 Industrial Circle

Longmont, CO 80501

Phone: 303.678.7500

800.742.2326

Fax: 303.678.7504

Email: [service@sens-usa.com](mailto:service@sens-usa.com)

Web: [www.sens-usa.com](http://www.sens-usa.com)

MADE IN U.S.A.

PATENT PENDING

Installation or service questions?  
Call SENS at 1.800.742.2326 (303.678.7500)  
between 8 a.m. and 5 p.m. (Mountain Time)  
Monday through Friday, or visit our website.

**TABLE OF CONTENTS**

**1 IMPORTANT SAFETY INSTRUCTIONS FOR INSTALLER AND OPERATOR .....4**

**2 QUICK INSTALLATION GUIDE .....5**

**3 PERFORMANCE SPECIFICATIONS .....6**

**4 MODEL NUMBER CONFIGURATION .....7**

**5 MECHANICAL INSTALLATION.....7**

5.1 Lifting .....7

5.2 Charger Mounting Options .....7

5.3 Ventilation.....7

5.4 Environmental Considerations .....8

**6 ELECTRICAL INSTALLATION.....8**

6.1 AC Input Connections.....9

6.2 DC Output Connections .....11

6.3 Alarm Wiring .....12

6.4 Operating Chargers in Parallel .....13

**7 POWER ON/POWER OFF PROCEDURES .....13**

7.1 Verify Input AC Supply .....13

7.2 Verify Battery Voltage.....13

7.3 Verify Charger Output .....13

7.4 Begin Charging .....13

7.5 Power Off.....13

**8 FRONT PANEL CONTROLS.....14**

8.1 Front Panel User Interface Description .....14

8.2 Commission Batteries .....15

8.3 Charge Mode Select .....15

8.3.1 Float Mode.....15

8.3.1.1 Battery Eliminator Operation .....15

8.3.2 Equalize Mode.....15

8.3.2.1 Manual Equalize Mode.....16

8.3.2.2 Demand Based Automatic Equalize Mode.....16

8.3.2.2.1 Dynamic Demand Based Automatic Equalize Mode.....16

8.3.2.2.2 Standard Demand Based Automatic Equalize Mode .....16

8.3.2.3 Periodic Automatic Equalize Mode .....17

8.4 Battery Check Feature.....17

8.5 Change Battery Type.....17

8.6 User Interface Display Menus.....18

8.6.1 User Interface Display Menu Instructions .....18

8.6.2 User Interface Menu Options .....18

8.6.3 Adjustment Limits/Voltage Setting Interlocks .....22

8.7 User Interface Mode—Unlock/Lock Jumper .....23

8.7.1 Expert Mode .....23

8.7.2 Normal Mode.....23

8.7.3 Monitor Only Mode.....23

**9 ALARMS .....24**

9.1 Summary Alarm Contact.....24

9.2 Individual Relay Alarm Contacts—*Optional*.....24

9.3 Alarm Definitions .....24

**10 BLACK BOX DATA RECORDER.....26**

10.1 Procedure to remove/install Black Box Data Recorder.....26

**11 TYPICAL SETTINGS.....27**

11.1 Typical Battery Settings .....27

**12 MAINTENANCE AND TROUBLESHOOTING .....28**

**LIST OF TABLES AND FIGURES**

---

Figure 1: Typical wiring diagram for IQ battery chargers .....8  
Figure 2: Input, output and alarm wiring locations .....9  
Table 1: AC Input Current and AC/DC Circuit Breaker Current Ratings..... 10  
Table 2: AC Input Wire Gauge Ratings ..... 10  
Table 3: DC Output Wire Gauge Ratings ..... 11  
Figure 3: Alarm contact terminal blocks ..... 12  
Table 4: Alarm contact designations ..... 13  
Table 5: Typical open circuit battery voltages for lead acid batteries..... 13  
Figure 4: Front Panel User Interface ..... 14  
Figure 5: Typical automatic charge sequence ..... 16  
Table 6: Default Battery Settings ..... 17  
Figure 6: User Interface Instructions..... 18  
Figure 7: Two temperature compensation curve examples ..... 21  
Figure 8: Charger Adjustment Limits for Flooded and VRLA Batteries ..... 22  
Figure 9: Charger Adjustment Limits for Nickel-Cadmium Batteries ..... 22  
Figure 10: Unlock/Lock Jumper..... 23  
Figure 11: Black Box Data Recorder ..... 26  
Table 7: Non-temperature compensated factory charger output voltage and alarm  
threshold settings for typical VRLA batteries ..... 27  
Table 8: Non-temperature compensated factory charger output voltage and alarm  
threshold settings for flooded lead acid batteries..... 27  
Table 9: Non-temperature compensated factory charger output voltage and alarm  
threshold settings for NiCd batteries ..... 28  
Figure 12: Troubleshooting chart for repeated AC breaker trip ..... 29  
Figure 13: Troubleshooting flowchart for AC fail alarm indication ..... 30  
Figure 14: Troubleshooting flowchart for charge fail alarm ..... 31  
Figure 15: Troubleshooting flowchart for DC output breaker trip ..... 32  
Figure 16: Troubleshooting flowchart for HIGH DC or OVSD alarms ..... 33  
Figure 17: Troubleshooting flowchart for LOW DC alarm ..... 34  
Figure 18: Troubleshooting flowchart for no output..... 35  
Figure 19: Troubleshooting flowchart for GROUND FAULT alarm ..... 36

## 1 IMPORTANT SAFETY INSTRUCTIONS FOR INSTALLER AND OPERATOR

---

### **WARNING:**

**HEATSINKS AND OTHER METALLIC SURFACES WITHIN THE CHARGER MAY BE ENERGIZED AT HIGH VOLTAGE POTENTIALS, WHICH CAN BE LETHAL. DO NOT TOUCH EXPOSED METAL SURFACES WITHIN THE CHARGER WHILE EITHER INPUT POWER OR BATTERY IS APPLIED.**

### **WARNING:**

**WORKING IN THE VICINITY OF A LEAD-ACID OR NICKEL-CADMIUM BATTERY IS DANGEROUS. STORAGE BATTERIES GENERATE EXPLOSIVE GASES DURING NORMAL BATTERY OPERATION. IT IS OF UTMOST IMPORTANCE THAT BEFORE USING YOUR CHARGER, YOU READ THIS MANUAL AND FOLLOW THE INSTRUCTIONS.**

- A. **SAVE THESE INSTRUCTIONS.**
- B. **DO NOT EXPOSE CHARGER TO RAIN OR SNOW.**
- C. **ONLY TRAINED AND QUALIFIED PERSONNEL MAY INSTALL AND SERVICE THIS UNIT.**
- D. **GROUNDING INSTRUCTIONS - This battery charger must be connected to a grounded metal permanent wiring system or an equipment-grounding conductor run with circuit conductors and connected to equipment-grounding terminal on battery charger. Connections to the battery charger must comply with all local codes and ordinances.**
- E. Do not operate charger if it has received a sharp blow, been dropped, or otherwise damaged in any way; shut off power at the branch circuit protectors, disconnect from battery power sources and have the unit serviced or replaced by qualified personnel.
- F. To reduce risk of electric shock, disconnect the branch circuit feeding the charger and disconnect the battery before attempting any maintenance or cleaning. Turning off controls will not reduce this risk.
- G. **Use this charger for charging FLOODED LEAD-ACID, VRLA or NICKEL-CADMIUM batteries only.** Do not use this battery charger for charging dry cells, alkaline, lithium, nickel-metal-hydride, or sealed nickel-cadmium batteries that are commonly used with home appliances. These batteries may burst and cause injuries to persons and damage to property.
- H. **NEVER** charge a frozen battery.
- I. To reduce the risk of battery explosion, follow these instructions and those published by the battery manufacturer and the manufacturer of any equipment you intend to use in the vicinity of a battery. Review cautionary markings on these products.
- J. Use of an attachment not recommended may result in a risk of fire, electric shock, or injury to persons.
- K. This equipment has been tested and found to comply with the limits for a Class B digital device, pursuant to Part 15 of the FCC Rules. These limits are designed to provide reasonable protection against harmful interference when the equipment is operated in a commercial environment. This equipment generates, uses, and can radiate radio frequency energy and, if not installed and used in accordance with the instruction manual, may cause harmful interference to radio communications. Operation of this equipment in a residential area is likely to cause harmful interference in which case the user will be required to correct the interference at his own expense.
- L. Notice to users in the European Union: Declaration of Conformity limits the use of chargers to non-public power grids.

## 2 QUICK INSTALLATION GUIDE

- A. Read all cautionary warnings in Section 1.
- B. Remove the charger from the packaging and inspect for damage. See Section 5.1 for information on moving and lifting the charger. Notify SENS immediately (1-800-742-2326) if damage from shipping is evident.
- C. See Section 5.2 for mounting options.
- D. All 120/208/240V (input codes P and T) models include a 3-way AC input voltage selection jumper. Ensure the AC voltage selection jumpers are in the correct position for your AC supply as shown below:

### VOLTAGE SELECT JUMPER SETTINGS

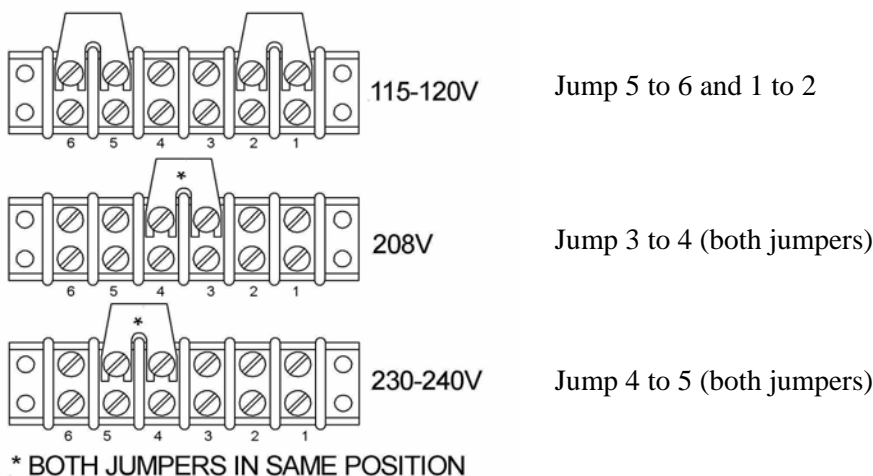

All 208/240V 60Hz (input code Z) models include a dual AC input voltage selection terminal block. Ensure the AC voltage wire is in the correct position for your AC supply as shown below:

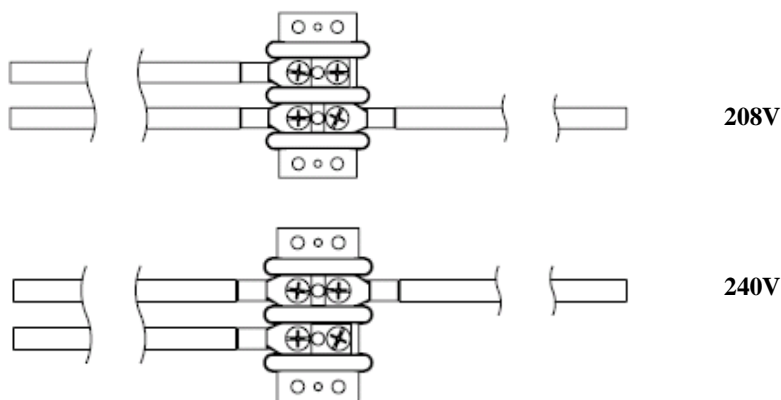

- E. Connect AC wires—**Ensure that the AC input supply is de-energized and the charger AC input circuit breaker is opened.** Wire the AC input circuit to the empty lugs of the AC input breaker. Connect the earthed conductor of the AC input circuit to the grounding lug inside the charger. See **TABLE 2** for AC input breaker wire size. See **FIG 1, FIG 2** and **DIA\00595** (back of manual) for wiring and breaker location.

- F. Connect DC wires—**Ensure that any battery disconnect device in the system, if used, is opened** (batteries disconnected from DC bus), and that the **DC output breaker in the charger is opened**. Connect the DC output wires to the load side of the DC output breaker, **observing the correct polarity** as labeled on the charger next to the output breaker. Make sure small signal leads also attached to the breaker remain connected. See **TABLE 3** for DC output breaker wire sizes. See **FIG 1, FIG 2** and **DIA\00595** (back of manual) for wiring and breaker location.
- G. Connect optional alarm wires—Alarm wiring enters the charger on the upper left side of the enclosure. Knock out the conduit opening and connect alarm wiring, taking care to route the wiring through appropriate cable guides provided within the charger. See **FIG 1, FIG 2, FIG 3** and **DIA\00595** (back of manual) for alarm wiring. See **TABLE 4** for alarm wiring connection locations.
- H. Energize the AC input supply at supply panel—**With the charger input AC and output DC breakers still opened**, energize the AC input supply, and check the voltage at the line (left) side of the input AC breaker, making sure it is the correct value for the charger.
- I. Verify battery voltage—**With the charger input AC and output DC breakers still opened**, close any system battery disconnect, if used, and measure the battery voltage at the battery (left) side of the charger DC output circuit breaker, making sure it is near the nominal DC voltage rating of the charger. See **TABLE 5** for typical values of open circuit battery voltage for most common battery configurations.
- J. Verify battery polarity—**With the DC output circuit breaker still opened**, close charger AC breaker to start charger. The charger status display will come on and the charger will execute its initialization routines. The charger output should ramp up to within 5% of battery voltage. It will not ramp up to the float voltage setting until the DC circuit breaker is closed.

**NOTE:**

**If a beeping tone is heard at this time, the polarity of the battery connection to the charger is incorrect. Turn off the AC power source and correct the reverse polarity problem.**

- K. Close the DC output breaker—Depending on the state of charge of the batteries and the load on the DC bus, the charger may go into current limit at this time, in which case the output voltage as displayed on the LCD will be reduced as the charger operates in constant current mode. Eventually as the battery is charged, the charging current demand should taper to a value below the current limit set point of the charger, and the charger should revert to constant voltage output.
- L. See Section 8.2 to initially charge/commission zero charge batteries.
- M. If Automatic or Equalize charging modes are desired press the **CHARGE MODE SELECT** button on the front panel (see **FIG 4** for CHARGE MODE selection and Section 8.2 for description of available charging modes). Set the **EQUALIZE TIME LIMIT** to the desired value (see Section 8.4.2).
- N. It is highly recommended that for proper operation of two chargers connected in parallel to the same battery that one charger be equipped with a CommsGenius communications option and is connected to the second charger with a digital load-sharing cable. See the CommsGenius User Manual available at [www.sens-usa.com](http://www.sens-usa.com) for more information. **The digital load sharing cable should never be connected when two chargers are each connected to different batteries.**

### 3 PERFORMANCE SPECIFICATIONS

---

See IQ Product Data Sheet at [http://www.sens-usa.com/en/products/energenius\\_iq/?PRODUCT\\_ID=20](http://www.sens-usa.com/en/products/energenius_iq/?PRODUCT_ID=20) for detailed performance specifications.

4 MODEL NUMBER CONFIGURATION

IQ	Nominal DC output			Rated output current			AC	Agency	Feature package			Alarm	Special Option
<b>Q</b>	<b>0</b>	<b>4</b>	<b>8</b>	<b>0</b>	<b>7</b>	<b>5</b>	<b>T</b>	<b>L</b>	<b>5</b>	<b>1</b>	<b>4</b>	<b>A</b>	<b>R</b>
	Ⓐ			Ⓑ			Ⓒ	Ⓓ	Ⓔ			Ⓕ	Ⓖ

	Parameter	Code	Value		Parameter	Code	Value
Ⓐ	Nominal DC output voltage	012 024 048 120 240	12 volts nominal 24 volts 48 volts 110-120 volts 220-240 volts	Ⓓ	Agency marks	L G S	UL & C-UL listed (60 Hz input units) UL & C-UL listed + CE marked (50/60 Hz input units) Special
Ⓑ	Rated output current	016 025 035 050 075 100 150	16 amps 25 35 50 75 100 150	Ⓔ	Feature package	511 512 514 534 574	<b>Filtered package</b> - Standard input breaker <b>Eliminator package</b> - Adds battery eliminator output filter to 511 <b>Eliminator Plus package</b> - Adds reverse polarity diode and blocking diode to 512 <b>Extreme package</b> - Adds 18-25K AIC input breaker and input inrush limiter to 514 <b>Extreme package</b> - With 65K AIC input breaker instead of 18-25K AIC. Available only in size Q2 cabinet.
Ⓒ	AC input, single phase	T P 3 S 8 4 V Z	120/208/240 V, 60 Hz 120/208/240 V, 50/60 Hz 208 V, 60 Hz (> 3.4 KW o/p) 240 V, 60 Hz (> 3.4 KW o/p) 480 V, 60 Hz 230V, 50/60Hz (> 3.4 KW o/p) 400 V, 50/60 Hz 208/240 V, 60 Hz	Ⓕ	Alarm relay and data communications package	A B C K L M N	Single Form C summary alarm relay Extended Individual Form C relays (AC fail, charger fail, low battery volts, high battery volts, ground fault, end of discharge, battery check) Standard Individual Form C relays (AC fail, charger fail, low battery volts, high battery volts, ground fault) CommsGenius Load Share* + Standard Alarms CommsGenius Load Share* CommsGenius Modbus* CommsGenius Modbus* + Standard Alarms *See CommsGenius User Manual for more information
				Ⓖ	Special option	E R	OSHPD labeled (California Special Seismic Cert Pre-Approval) Rack mount

5 MECHANICAL INSTALLATION

5.1 Lifting

The charger is designed to be lifted either from the bottom by pallet jack or lift truck or from the top via a strap and hook arrangement attached to four 3/8 inch eyebolts (not provided) installed in the top of the unit. See drawings at back of manual for eyebolt installation locations.

5.2 Charger Mounting Options

The charger is designed to accommodate either wall or floor mounting. The charger has integral wall mounting flanges on the sides of the chassis. Floor pieces can be ordered as optional kits. See drawings at back of manual for details on mounting configurations. Do not mount the charger in locations subject to high vibration. Do not mount the charger directly to the frame of an engine or generator set.

5.3 Ventilation

The charger is designed to be convection cooled. Required clearances around the unit for proper cooling are 6 inches on the top and 4 inches on the bottom.

5.4 Environmental Considerations

The charger should be installed in a sheltered area, protected from rain and snow. The suggested operating temperature range is  $-20^{\circ}\text{C}$  to  $+50^{\circ}\text{C}$ , but the charger will operate safely outside of this range. The charger is rated for  $-40^{\circ}\text{C}$  for black/cold start, and once it self heats to  $-20^{\circ}\text{C}$  is guaranteed to meet all published specifications. The charger thermal limiter reduces output current to prevent over-heating when ambient temperature is too high.

6 ELECTRICAL INSTALLATION

**WARNING:**  
**BEFORE ELECTRICAL INSTALLATION, ENSURE THE FOLLOWING:**

- A. AC MAINS SUPPLY CIRCUIT IS DE-ENERGIZED.**
- B. AC INPUT BREAKER ON THE CHARGER IS OPENED**
- C. DC OUTPUT BREAKER ON THE CHARGER IS OPENED**
- D. BATTERY DISCONNECT, IF USED, IS OPENED (BATTERY REMOVED FROM DC BUS).**

See wiring diagram in FIG 1. This diagram reflects charger setup for a typical installation only. For applications not covered in the diagram, please consult your charger supplier.

See drawings at back of manual for quick reference installation information.

Figure 1: Typical wiring diagram for IQ battery chargers

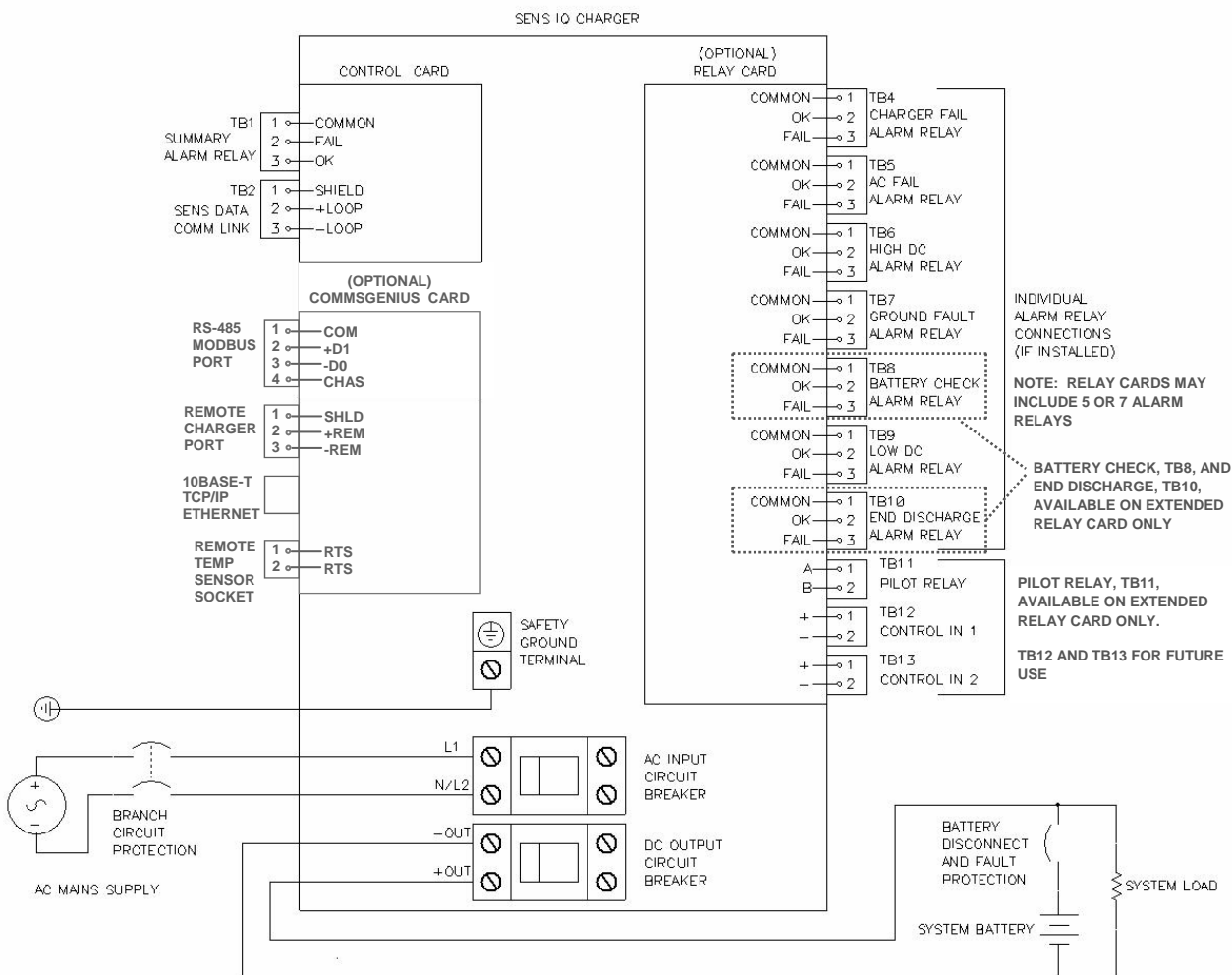



**6.1 AC Input Connections**

The battery charger is designed to be permanently connected to an appropriately rated single phase, grounded AC mains circuit. Wiring used must be sized appropriately for the charger input current and must be selected to meet any applicable local codes (see **TABLE 1** for charger circuit breaker ratings and **TABLE 2** for recommended wire gauges). Connect to the line side of the input circuit breaker and ground lug via conduit knockout openings on the lower left side of the charger enclosure (see **FIG 2**). The earthed conductor of the AC mains circuit must be connected to the charger-grounding terminal. Input (AC line) wiring must be kept at least 1/4" (6.3 mm) away from all output, alarm, data interface wiring, and from other uninsulated electrical parts not connected to the input conductor.

**Figure 2: Input, output and alarm wiring locations (circuit breaker appearance may vary depending on model)**

**ALARM RELAY PRINTED CIRCUIT BOARD/ COMMSGENIUS (REMOTE TEMP SENSE, LOAD SHARE AND COMMUNICATIONS)**

(Optional. 5 or 7 alarm relays may be mounted as shown. CommsGenius may be mounted in same location with or without 5 alarm relay printed circuit board.)

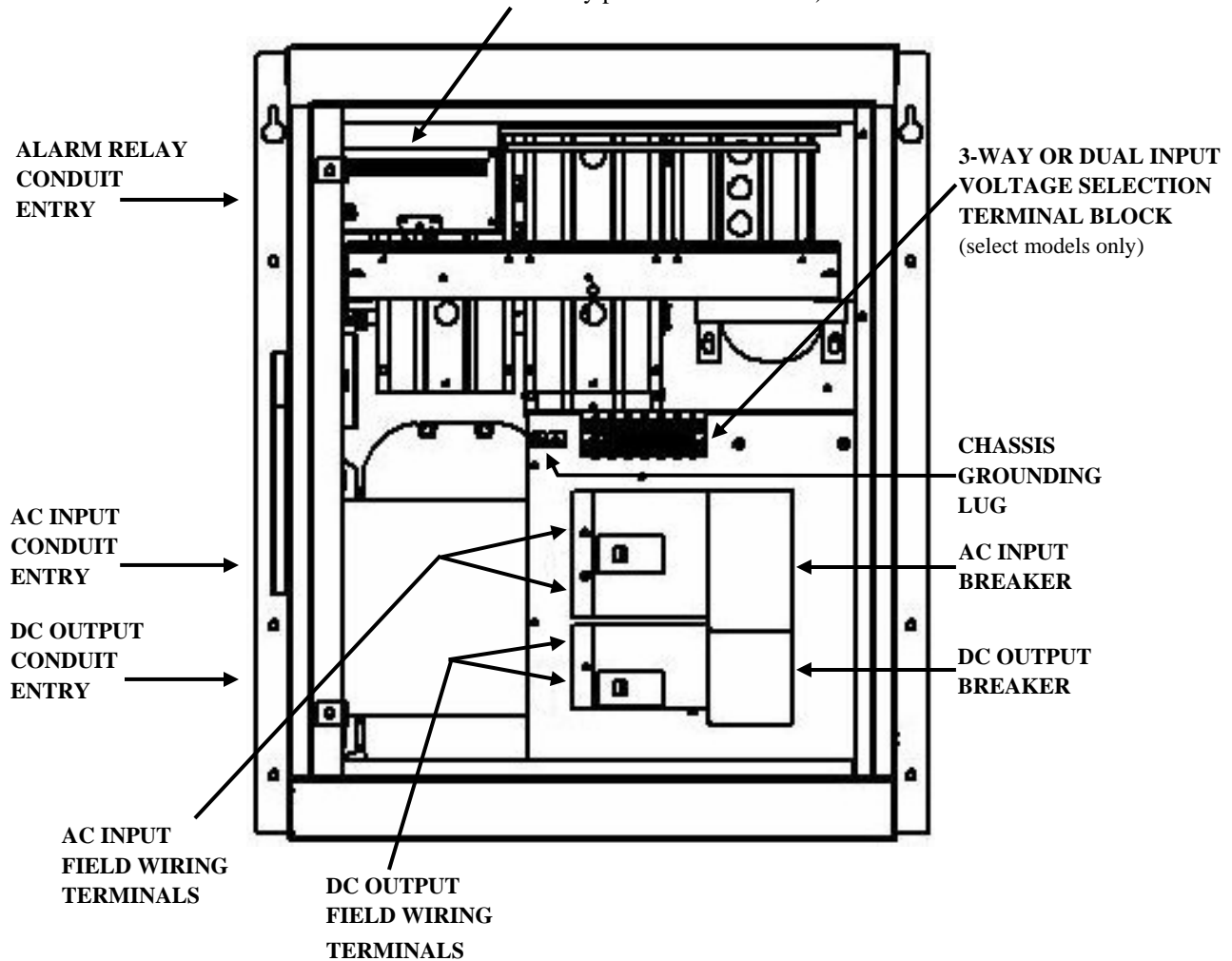

**NOTE:**

Control Printed Circuit Board is located on inside of charger front door.

**Table 1: AC Input Current and AC/DC Circuit Breaker Current Ratings**

Charger Model	Rated AC Input Current					*AC Input Branch Circuit Breaker Ratings							Charger Input Breaker Current Ratings					Charger Output Breaker Current Ratings
	208V 60Hz (3), 208/240V 60Hz (Z)	230/240V 50/60 Hz (4), 60Hz (S)	480V 60Hz (8)	120/208/240V 50/60Hz (P), 60Hz (T)	400V 50/60 Hz (V)	208V 60Hz (3), 208/240V 60Hz (Z)	230/240V 50/60 Hz (4), 60Hz (S)	480V 60Hz (8)	120V 50/60 Hz (P), 60Hz (T)	208V 50/60 Hz (P), 60Hz (T)	240V 50/60 Hz (P), 60Hz (T)	400V 50/60 Hz (V)	208V 60Hz (3), 208/240V 60Hz (Z)	230/240V 50/60 Hz (4), 60Hz (S)	480V 60Hz (8)	120/208/240V 50/60 Hz (P), 60Hz (T)	400V 50/60 Hz (V)	
Q012-075	N/A	N/A	4.6	18/11/9.1	5.5	N/A	N/A	15	25	15	15	15	N/A	N/A	15	25	15	100
Q012-100	N/A	N/A	6.1	24/14/12	7.3	N/A	N/A	15	30	20	15	15	N/A	N/A	15	30	15	125
Q012-150	N/A	N/A	9.0	36/21/18	11	N/A	N/A	15	45	30	25	15	N/A	N/A	15	45	15	200
Q024-075	N/A	N/A	8.3	33/19/17	9.9	N/A	N/A	15	45	25	25	15	N/A	N/A	15	45	15	100
Q024-100	N/A	N/A	11	44/25/22	13	N/A	N/A	15	60	35	30	20	N/A	N/A	15	60	20	125
Q024-150	37	32	16	N/A	19	50	40	20	N/A	N/A	N/A	25	50	40	20	N/A	25	200
Q048-075	34.1	30	15	N/A	18	45	40	20	N/A	N/A	N/A	25	45	40	20	N/A	25	100
Q048-100	45	39	20	N/A	24	60	50	25	N/A	N/A	N/A	30	60	50	25	N/A	30	125
Q120-035	38	33	17	N/A	20	50	45	25	N/A	N/A	N/A	25	50	45	25	N/A	25	45
Q120-050	54	46	23	N/A	28	70	60	30	N/A	N/A	N/A	40	70	60	30	N/A	40	70
Q240-016	35	30	15	N/A	18	50	40	20	N/A	N/A	N/A	25	50	40	20	N/A	25	20
Q240-025	54	46	23	N/A	28	70	60	30	N/A	N/A	N/A	40	70	60	30	N/A	40	35

\*User must incorporate a branch circuit breaker external to the charger to provide a mode of disconnection from the supply mains.

**Table 2: AC Input Wire Gauge Ratings**

Rated Charger Input	Wire Gauge	
	Min	Max
≤ 240 VAC, 60Hz	# 14 Cu or Al	#2 Cu or Al
≤ 240 VAC, 50/60Hz	# 14 Cu, #12 Al	# 1/0 Cu or Al
> 240 VAC	# 14 Cu, #12 Al	# 1/0 Cu or Al
All 65 KAIC Breakers (Special Order)	# 14 Cu, #12 Al	# 1/0 Cu or Al

**NOTE:**

Table 2 represents only the physical capabilities of the terminals. In addition to the physical limitations, conductors must be electrically adequate per local electrical safety regulations (such as the National Electrical Code®).

6.2 DC Output Connections

**WARNING:**  
**OBSERVE PROPER POLARITY WHEN CONNECTING THE BATTERY CIRCUIT TO THE CHARGER. FAILURE TO DO SO COULD RESULT IN EXPLOSION AND DAMAGE TO THE BATTERY CHARGER. SHOULD THE BATTERY CONNECTIONS BE REVERSED, A BEEPING TONE WILL BE HEARD WHEN AC POWER IS APPLIED. IF THIS TONE IS HEARD, RECHECK BATTERY AND SENSE LEAD CONNECTIONS TO OUTPUT BREAKER FOR PROPER POLARITY BEFORE CLOSING THE DC CIRCUIT BREAKER OR OPERATING THE CHARGER.**

The battery charger is designed for permanent connection to the battery and DC load circuit, as shown in FIG 1. Wiring used must be sized appropriately for the charger output current and must be selected to meet any applicable local codes (see TABLE 1 for circuit breaker ratings and TABLE 3 for wire gauges). Connection is made to the load side of the output circuit breaker via conduit knockout openings on the lower left side of the charger enclosure. Proper polarity for connection to the circuit breaker is labeled on the inside of the charger near the output circuit breaker. Output (DC battery) wiring must be kept at least 1/4" (6.3mm) away from all alarm and data interface wiring, and from other uninsulated electrical parts not connected to the output conductor.

The battery may be disconnected (for test or replacement purposes) while leaving the charger powered on without interrupting the load. With battery disconnected, on charger with 2% filter, the maximum transient voltage deviation is 5% of initial voltage when subjected to load current changes between 20% to 100% and 100% to 20% of full rated load current. Recovery to within 1% of steady state voltage is within 200 milliseconds. Transient response in units with battery eliminator output filter is slower.

**CAUTION:**  
 Small sense leads are connected to the load (output) side of the DC output circuit breaker. These must remain connected with the proper polarity after installation of the output power DC wiring or the charger will not function properly.

**NOTE:**  
 If required for your installation, either the positive or the negative charger output may be connected to earth ground. If this is done, the ground fault alarm must be disabled to prevent a false alarm (see Section 8.4.2 to configure the ground fault alarm).

**Table 3: DC Output Wire Gauge Ratings**

Rated Charger Output		Wire Gauge	
Volts	Current	Min	Max
12V - 48V	≤ 50A	# 14 Cu or Al	# 2 Cu or Al
	75 & 100A	# 4 Cu or Al	# 2/0 Cu or Al
	150A	#4 Cu Only	# 4/0 Cu Only
120V & 240V	≤ 16A	# 14 Cu, #12 Al	# 4 Cu or Al
	≥ 25A	# 14 Cu, #12 Al	# 1/0 Cu or Al

**CAUTION:**  
 Output terminals on 150A models are approved for use with copper conductors only. Do not use aluminum output conductors for 150A models.

**NOTE:**  
 Table 3 represents only the physical capabilities of the terminals. In addition to the physical limitations, conductors must be electrically adequate per local electrical safety regulations (such as the National Electrical Code®).

6.3 Alarm Wiring

**WARNING:**  
**CONNECT ALARM TERMINALS ONLY TO LIMITED ENERGY (“CLASS 2” or “CLASS 3”) CIRCUITS. ALARM AND PILOT RELAYS ARE RATED 26VDC AT 2.0A AND 125VAC AT 0.25A (RESISTIVE) MAXIMUM.**

Each charger comes standard with one Summary alarm that allows the user to monitor several alarms at once with one set of dry contacts. Connect alarm wiring to the Summary alarm terminal block on the Control Printed Circuit Board (see FIG 3).

Two different individual alarm relay package options are available, only one of which can be installed at a time. The Standard Alarm Relay Printed Circuit Board offers five alarm discrete Form C contacts. The Extended Alarm Relay Printed Circuit Board offers seven discrete Form C contacts plus a pilot relay. The pilot relay automatically closes when the charger enters EQUALIZE mode, and opens when the charger reverts to FLOAT mode (see FIG 3). Connect additional alarm wiring to the alarm terminal blocks on either Alarm Relay Printed Circuit Board (see FIG 3). See TABLE 4 for alarm pin designations. The alarm wires should be connected from COM, through user supervisory system, then to either FAIL or OK.

Conduit knockouts are provided on the upper right side of the charger for alarm wires (see FIG 2). Wire gauge between 14 and 28AWG may be used for the alarm connection wires. Alarm and data interface wiring must be kept at least 1/4" (6.3mm) away from input conductors, output conductors, and from other uninsulated electrical parts not connected to the alarm or data conductor. Use the provided wire positioning devices to hold alarm and data wiring away from other circuits and hot surfaces.

Figure 3: Alarm contact terminal blocks

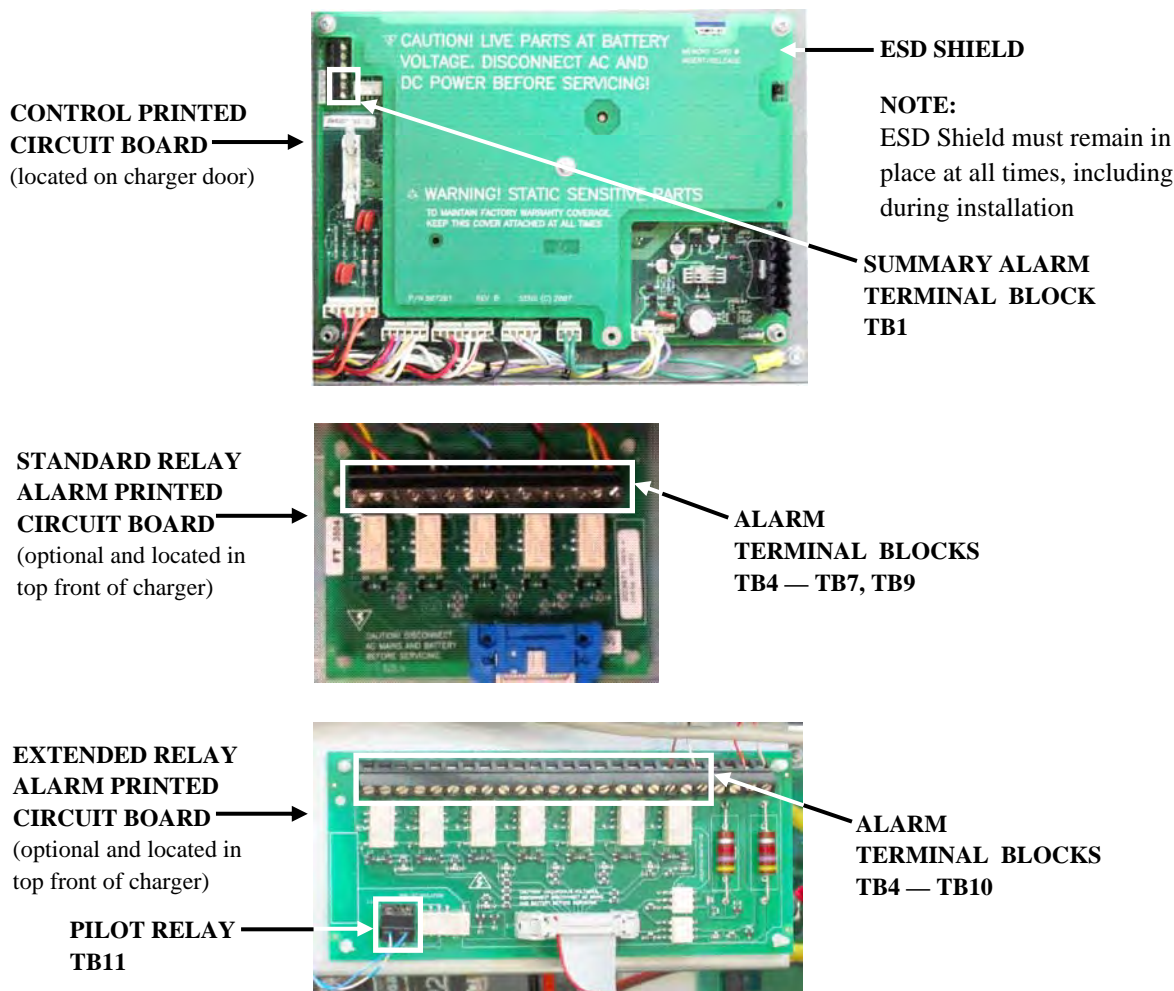

**Table 4: Alarm contact designations** (Standard and Extended Alarm Relay Printed Circuit Boards)

RELAY CONTACTS	ALARM FUNCTION							
	SUMMARY (on Control PWA)	CHARGER FAIL	AC FAIL	HIGH DC	GROUND FAULT	BATTERY CHECK (Extended Only)	LOW DC	BATTERY END-OF-DISCHARGE (Extended Only)
COMMON	TB1-1 COM	TB4-1 COM	TB5-1 COM	TB6-1 COM	TB7-1 COM	TB8-1 COM	TB9-1 COM	TB10-1 COM
OPEN ON ALARM	TB1-2 OK	TB4-2 OK Defaults to OK with no AC input	TB5-2 OK	TB6-2 OK Defaults to OK with no AC input	TB7-2 OK Defaults to OK with no AC input	TB8-2 OK Defaults to OK with no battery	TB9-2 OK	TB10-2 OK
CLOSE ON ALARM	TB1-3 FAIL Defaults to FAIL with no battery and no AC input	TB4-3 FAIL	TB5-3 FAIL Defaults to FAIL with no AC input	TB6-3 FAIL	TB7-3 FAIL	TB8-3 FAIL	TB9-3 FAIL Defaults to FAIL with no battery	TB10-3 FAIL Defaults to FAIL with no battery

#### 6.4 Operating Chargers in Parallel

It is highly recommended that for proper operation of two chargers connected in parallel to the same battery that one charger be equipped with a CommsGenius communications option and is connected to the second charger with a digital load-sharing cable. See the CommsGenius User Manual available at [www.sens-usa.com](http://www.sens-usa.com) for more information. **The digital load sharing cable should never be connected when two chargers are each connected to different batteries.**

## 7 POWER ON/POWER OFF PROCEDURES

### 7.1 Verify Input AC Supply

With the input AC and output DC breakers open, connect a portable voltmeter to the line side of the input AC breaker on the charger. Energize the AC supply at main electrical panel and verify it is within acceptable range.

### 7.2 Verify Battery Voltage

With the input AC and output DC breakers open, connect a portable voltmeter to the load side of the DC breaker and verify that the open circuit battery voltage is within acceptable range (see **TABLE 5** below). See Section 8.2 to initially charge/commission zero charge batteries.

**Table 5: Typical open circuit battery voltages for lead acid batteries**

Number of Cells	6	12	24	55	60	110	120
Nominal Charger Output Voltage	12	24	48	110	120	220	240
Open Circuit Voltage	12.0-12.9	24.0-25.8	48.0-51.6	110-118	120-129	220-237	240-258

### 7.3 Verify Charger Output

Connect a portable voltmeter to the line side of the charger DC output circuit breaker. With the front panel CHARGE MODE SELECT button, ensure the charger is in FLOAT mode (See Section 8.2). With the charger DC output circuit breaker still open, close the charger AC input circuit breaker and verify that charger output comes up to its nominal float setting. It should take less than 30 seconds for the charger output to reach its final value.

### 7.4 Begin Charging

Close the DC output breaker. Depending on the state of charge of the batteries and the load on the DC bus, the charger may go into current limit at this time, in which case the output voltage as displayed on the LCD will be reduced as the charger operates in constant current mode. Eventually as the battery is charged, the charging current demand should taper to a value below the current limit set point of the charger, and the charger should revert to constant voltage output, regulating the DC bus at the float level.

### 7.5 Power Off

Power off the charger by opening the AC and DC breakers, in any order.

## 8 FRONT PANEL CONTROLS

### 8.1 Front Panel User Interface Description

The front panel User Interface provides visual indication of DC output voltage and current, as well as the charging mode (FLOAT or EQUALIZE), equalize time elapsed, and status of all alarms. The front panel User Interface is shown below in FIG 4.

**NOTE:**

With no AC mains supply present and with a battery connected to the output of the charger, and with the DC output breaker closed, the display will operate. Battery voltage and alarm status will be displayed. With the system in this condition, the charger draws between 200 and 240mA from the battery.

**Figure 4: Front Panel User Interface**

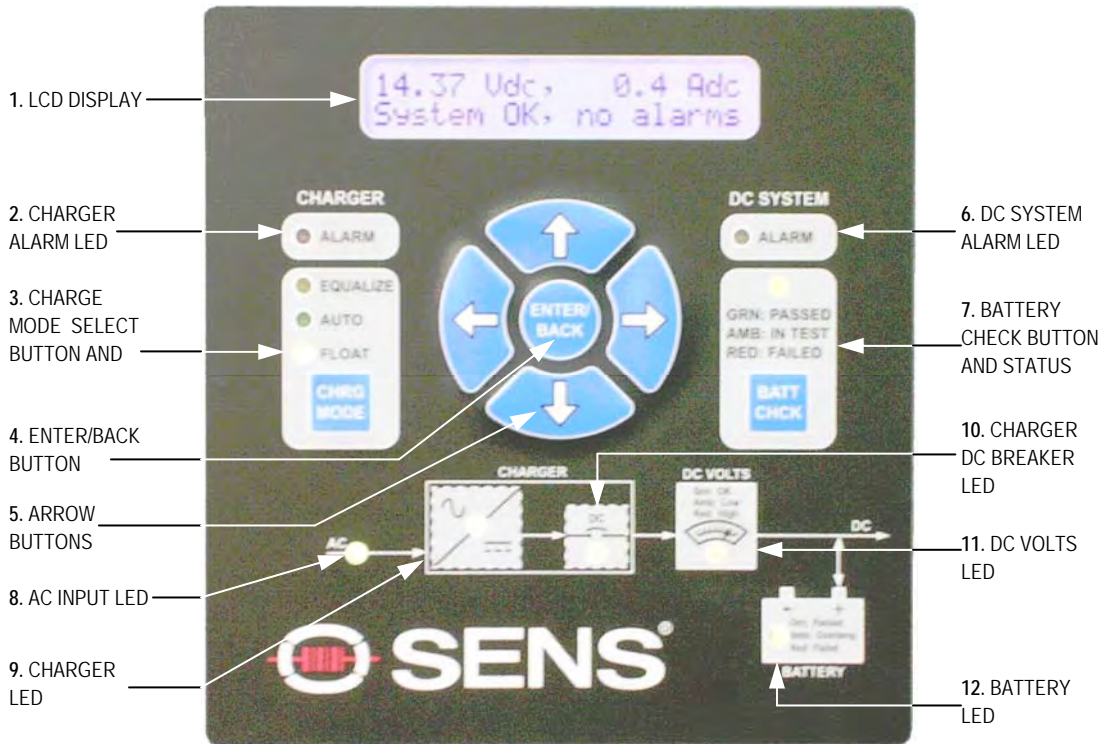

1. **LCD DISPLAY** - During normal operation the first line of the LCD display indicates DC output voltage and current and the second line indicates alarm status. The display will automatically cycle through alarm status when any alarms are present. Display will change as User Interface buttons are pressed, to show different menus and configuration choices. The output voltage display is accurate to within  $\pm 1\%$ . The Output current display is accurate to within  $\pm 1\%$  or better at room temperature at rated output.
2. **CHARGER ALARM LED** - this is a red master LED indicating any of the following problems: Over Voltage Shutdown, DC Breaker Open or Charger Failure alarm (see Section 9.3 for Alarm Definitions). A blank LED indicates no alarm conditions present.
3. **CHARGE MODE SELECT BUTTON AND STATUS LEDES** - Press CHRG MODE button to switch between FLOAT, EQUALIZE or AUTO modes (See Section 8.3). The appropriate LED will illuminate to indicate which mode is active.
4. **ENTER/BACK BUTTON** - Press ENTER/BACK to save a setting or move backward within the User Interface menus (see Section 8.6.2 for Menu Options).
5. **ARROW BUTTONS** - Press arrow buttons to move through User Interface menus and increase/decrease configurable values (see Section 8.6.2 for Menu Options).



6. **DC SYSTEM ALARM LED** - this is a red master LED indicating any of the following problems: Battery Reverse Polarity, High DC Voltage, Battery Check failed, Battery End-of-Discharge, Low DC Voltage (see Section 9.3 for Alarm Definitions). Amber indicates a Ground Fault or Battery Discharging alarm. Press the ENTER/BACK key twice to clear a red LED after a failed Battery Check test. Otherwise, a blank LED indicates no alarm conditions present.
7. **BATTERY CHECK BUTTON AND STATUS LED** - Press BATT CHCK to activate the Battery Check feature (see Section 8.4). The status LED displays test progress and outcome. Amber indicates the test is in progress. Green indicates the Battery Check passed successfully. Red indicates the Battery Check test failed. The status LED is blank if a Battery Check test has not occurred, if the Battery Check feature is disabled, at start up after a previously passed test, after a field battery change, if a Battery Check test is terminated prematurely, or after pressing the ENTER/BACK key twice to clear the alarm LED.  
  
If the Battery Check is successful the BATTERY LED will also be Green. If the Battery Check fails the DC SYSTEM LED and BATTERY LED will be Red.
8. **AC INPUT LED** - Indicates AC input power status. Green indicates correct AC input power is present, Amber indicates AC voltage is out of specification, Red indicates no AC power is present.
9. **CHARGER LED** - Indicates charger status. Green indicates a normally operating charger, Amber indicates a Charger Over Temperature warning, Red indicates an Over Voltage Shutdown or Charger Failure alarm. See LCD display for specific alarm indication while alarm is present.
10. **CHARGER DC BREAKER LED** - Indicates DC breaker status. Green indicates DC breaker is closed, Red indicates DC breaker is open.
11. **DC VOLTS LED** - Indicates DC output voltage status. Green indicates DC voltage is normal, meaning above Low DC Voltage alarm setting and below High DC Voltage alarm setting. Amber indicates a Low DC Voltage or Battery End-of-Discharge alarm, Red indicates a High DC Voltage or Over Voltage Shutdown alarm.
12. **BATTERY LED** - Indicates battery status. Green indicates that battery passed a Battery Check, Amber indicates a Battery Over Temperature alarm, Red indicates a Battery Backwards or Battery Check Fail alarm. Blank indicates a Battery Check test has not occurred, the Battery Check feature is disabled, or the battery type or cell count has changed.

## 8.2 Commission Batteries (available with version 3.00 or later firmware)

Initially charge/commission zero charge batteries or when recommended by a battery manufacturer by scrolling to the COMMISSION CHRГ menu on the front panel User Interface Display. The user interface jumper must be in the unlock position to engage commissioning (see Section 8.7). Once commissioning has started, the jumper should be placed back in the lock position. See Section 8.6.2 to adjust commission charge settings. Commissioning is timed and uses configurable voltage and current settings. Commissioning is not available for VRLA batteries. During commissioning, High DC and Over Voltage Shutdown alarms occur at 102% of the commissioning charge voltage and temperature compensation is not active. After commissioning completes, the charger will automatically revert to the settings configured for normal charging, including temperature compensation and high voltage alarms.

## 8.3 Charge Mode Select

The charging mode of the battery charger is controlled via the front panel CHARGE MODE SELECT button, as shown in FIG 4. The charger may be operated in any one of three modes, FLOAT, EQUALIZE or AUTO.

### CAUTION:

Always read and follow battery manufacturer's recommendations regarding float and equalize charge settings.

### 8.3.1 Float Mode

The FLOAT mode is used to maintain the battery in its fully charged state, and is the normal setting for all batteries and the preferred setting for most Valve Regulated Lead Acid (VRLA) batteries. With the charger in the FLOAT setting, the output voltage is maintained at the float voltage setting.

#### 8.3.1.1 Battery Eliminator Operation

The charger is designed to operate in a stable fashion when driving DC loads either with or without a battery connected. Chargers intended for use without a battery connected should be adjusted so that Float output voltage is set to the nominal rating of the charger and Equalize Mode, Temperature Compensation, Battery Check button and automatic Battery Check are disabled (see Section 8.6.2).

### 8.3.2 Equalize Mode

The EQUALIZE mode is used to ensure that all battery cells in a battery string are charged to the same level, and also used when faster charging of the batteries is desired, such as recovery after a power failure. The output voltage of the charger is typically 5%-10% higher in EQUALIZE mode than in FLOAT mode.

**8.3.2.1 Manual Equalize Mode**

Press the front panel CHARGE MODE SELECT button to engage manual EQUALIZE mode. The Amber Equalize LED will illuminate. With the charger in the EQUALIZE setting, the output voltage is maintained at the equalize voltage until the equalize time period (see Section 8.3) has expired, or the FLOAT setting is selected manually with the front panel CHARGE MODE SELECT button. If the charger is switched from EQUALIZE to FLOAT, then back to EQUALIZE, this resets the equalize time period.

**8.3.2.2 Demand Based Automatic Equalize Mode**

Press the front panel CHARGE MODE SELECT button to engage AUTO mode and see Section 8.4.2 to activate either Standard or Dynamic Demand Based EQUALIZE.

**CAUTION:**

For systems with a large amount of continuous DC load (load separate from battery charging current) the AUTO setting may force the charger into equalize charging mode for longer than is required by the battery, possibly causing excessive charging of the battery. This should be taken into account in the design of the system and in the choice of charge mode setting.

**8.3.2.2.1 Dynamic Demand Based Automatic Equalize Mode** (factory default setting, available with version 3.00 or later firmware)

Dynamic Demand Based Automatic EQUALIZE mode provides a battery interactive automatic EQUALIZE cycle in a manner similar to that described below for Standard Demand Based Automatic EQUALIZE, but automatically adapts to each application in real time by compensating for depth of discharge, varying load, battery age and other variables. This Dynamic Equalize™ mode safely maximizes recharge performance while cutting risk of overcharge that is associated with prolonged fixed charge cycles or excessive EQUALIZE settings. This mode is preferable to the standard method due to overall better recharge performance.

**8.3.2.2.2 Standard Demand Based Automatic Equalize Mode**

Standard Demand Based Automatic EQUALIZE mode provides a battery interactive automatic EQUALIZE cycle in which the charger measures the output current to determine state of charge of the battery. With the charger in the AUTO mode and Demand Based EQUALIZE active, when the output current of the charger exceeds about 95% of its adjustable current limit setting, the charger enters EQUALIZE mode. As the output current tapers off to less than about 70% of the adjustable current limit setting, the charger reverts to FLOAT mode. If the equalize time period has expired while in Demand Based EQUALIZE, the charger mode selector automatically reverts to FLOAT. If the charger is switched from AUTO to FLOAT, then back to AUTO, this resets the equalize time period. A typical automatic charge sequence is shown in FIG 5.

**Figure 5: Typical automatic charge sequence**

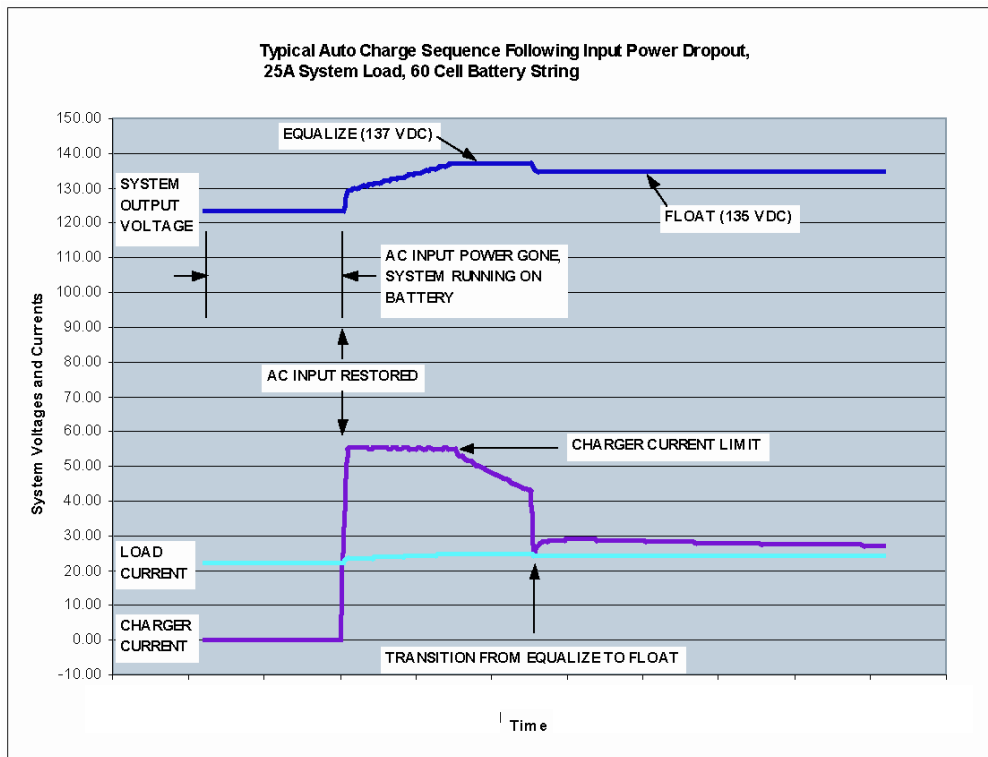



**8.3.2.3 Periodic Automatic Equalize Mode**

Press the front panel CHARGE MODE SELECT button to engage AUTO mode and see Section 8.4.2 to configure and activate Periodic EQUALIZE. The Periodic Automatic EQUALIZE mode provides an automatic EQUALIZE cycle on a regular interval configured by the user. When in EQUALIZE mode, the charger will revert to FLOAT mode when the equalize time period has expired. If the charger is switched from AUTO to FLOAT, then back to AUTO, this resets the equalize time period. The charger will immediately begin a Periodic Automatic EQUALIZE upon pressing the CHARGE MODE SELECT button to engage AUTO mode.

**8.4 Battery Check Feature**

Activate the Battery Check Feature via the front panel BATT CHCK button, as shown in FIG 4. Upon pressing the button once, the display will prompt the user to press the button again to engage the Battery Check test. The test will reduce the charger’s output voltage setpoint to a “backstop” level to permit the battery to support the load. Upon completion of the test, the LCD and status LED will display whether the test passed or failed, meaning whether or not the battery supported the load. The DC SYSTEM LED and BATTERY LED (see Section 8.1) will also reflect whether or not the battery test passed or failed.

**IMPORTANT:** A load under 3% of the charger’s maximum current rating may cause inaccurate battery check results. If the system load is typically lower than 3% disable the periodic automatic battery check feature via the front panel keypad. See Section 8.6.2 to configure Battery Check parameters.

Schedule Battery Check to run automatically by enabling Periodic Auto Battery Check via the front panel keypad.

**NOTE:** When an in-process periodic battery check is aborted by pressing the ENTER/BACK button the periodic schedule is updated as if the battery check ran to completion but battery check results are not updated.

**8.5 Change Battery Type** (available with version 3.00 or later firmware)

Change the type of system battery by scrolling to the UNIT SETUP menu on the front panel User Interface Display. The user interface jumper must be in the unlock position to change battery type (see Section 8.7) and should be placed back in the lock position when finished. Selecting a different battery type automatically changes cell count, float, equalize and alarm values. New battery type settings, including default charge and alarm voltage values, are applied immediately and become permanent upon exiting the user interface (by navigating to and remaining at home menu or when user interface automatically returns to home menu due to inactivity). Default values are shown in TABLE 6. See Section 8.6.2 to apply custom charging or alarm voltage values after making the battery type change. Changing to the same battery type already selected will not change any settings.

**Table 6: Default Battery Settings (volts per cell)**

SETTING	VRLA					FLOODED LEAD-ACID					NICKEL-CADMIUM				
	12V	24V	48V	120V	240V	12V	24V	48V	120V	240V	12V	24V	48V	120V	240V
Battery Cell Count	6	12	24	60	120	6	12	24	60	120	10	19	37	92	184
Float Voltage	2.27					2.22					1.43				
Equalize Voltage	2.30					2.30					1.52				
Low DC	1.83					1.83					1.19				
Battery Discharging	2.00					2.00					1.30				
Battery End-of-Discharge	1.75					1.75					1.13				
High DC	2.44					2.47					1.61				
Over Voltage Shutdown	2.53					2.568					1.67				

8.6 User Interface Display Menus

8.6.1 User Interface Display Menu Instructions

The IQ charger User Interface uses an X-Y navigation system with main fields up and down, and details within each field left and right (see FIG 6). Press the up and down arrow keys to scroll through main menu options. Press the left and right arrow keys to scroll through data available within each menu. Value adjustments are made with the up and down arrow keys. See Section 8.4.2 for a description of Menu Options.

Figure 6: User Interface Instructions

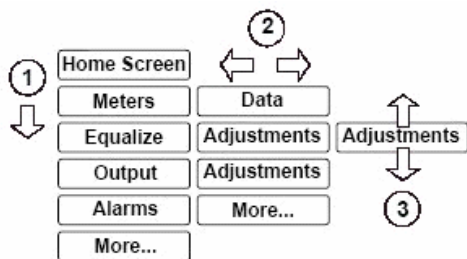

LCD Navigation

- ① ↑ or ↓ keys for main fields
- ② ← or → for details within each field
- ③ to adjust value press ↑ or ↓

ENTER returns to main fields

2x ENTER returns to Home screen

8.6.2 User Interface Menu Options

Ensure User Interface Mode is set to the appropriate level of access before attempting to adjust parameters (see Section 8.7). If an option described below is not displayed on the front panel LCD it is likely because the option or an associated parameter is not set to active. Absolute maximum voltage limits apply to all output and alarm settings. The maximum volts-per-cell given in the table will not be available for all cell counts.

Main Menus <i>(Press up and down arrows to scroll through Main Menu Options)</i>	Configurable/Viewable Parameters <i>(Press left and right arrows to scroll through choices within each Menu Option)</i>	Parameter Descriptions/Definitions
COMMISSION CHRG <i>(available with version 3.00 or later firmware)</i>	Commission Volts	Adjust commissioning VpC setpoint. Charger will deliver this voltage upon entering commissioning charge cycle. Adjustable from 2.000 - 2.585 VpC for flooded lead acid and 1.200 - 1.600 VpC for NiCd batteries. Not available for VRLA batteries.
	Commission Amps	Adjust commissioning amps value from 5% to 110% of nominal current rating.
	Commission Time	Adjust the amount of time from 1 to 120 hours that the charger output commissioning charge voltage.
	Commission Battery	Press UP arrow to begin commissioning charge and DOWN arrow to terminate.
METERS & DATA	Equalize time remaining	View amount of time charger will remain in EQUALIZE mode. Only displayed when charger is currently in EQUALIZE mode.
	Equalize time elapsed	View amount of time charger has been in EQUALIZE mode. Only displayed when charger is currently in EQUALIZE mode.
	DC volt meter	View existing Volts per Cell (VpC) and total output voltage. Following screen notes whether or not Temperature Compensation is active.
	DC setpoint @ 25°C	View what the FLOAT voltage setpoint in VpC and total output voltage would be at 25°C ambient temperature if the Temperature Compensation system were disabled.
	DC setpt @ temp now	View the temperature compensated FLOAT voltage setpoint in VpC and output voltage at existing ambient temperature
	AC input meter	View AC input voltage as a percentage of nominal AC voltage

Table continued on next page

<b>Main Menus</b> <i>(Press up and down arrows to scroll through Main Menu Options)</i>	<b>Configurable/Viewable Parameters</b> <i>(Press left and right arrows to scroll through choices within each Menu Option)</i>	<b>Parameter Descriptions/Definitions</b>
<b>EQUALIZE VALUES</b>	Equalize time limit	Adjust the amount of time from 1 to 255 hours that the charger will be in EQUALIZE mode. A time limit is put on the equalize portion of the charge cycle when in AUTO or EQUALIZE mode to prevent unlimited operation in EQUALIZE mode. The equalize time limit is reset if the charger is switched from AUTO or EQUALIZE charge mode to FLOAT charge mode, then back to AUTO or EQUALIZE charge mode. The equalize timer is also reset if an AC fail alarm occurs.
	Equalize V setting	Adjust EQUALIZE VpC setpoint. Charger will deliver this voltage upon entering EQUALIZE mode. Adjustable from 2.00 - 2.45 VpC for flooded lead acid and VRLA batteries, 1.20 - 1.60 VpC for NiCd. May not be lower than float setting. Must be lower than High DC volt alarm setting by at least 2% nominal battery voltage.
	Demand based automatic equalize	Set to ON or OFF. Enable or disable Demand Based Automatic EQUALIZE (see Section 8.3.2.2).
	Periodic automatic equalize	Set to ON or OFF. Enable or disable EQUALIZE on a periodic interval configured by user.
	Days between periodic equalize	Adjust the amount of time from 1 to 180 days between periodic EQUALIZE events
	Minute equalize delay after restart	Adjust the amount of time from 0 to 5 minutes to delay before entering EQUALIZE mode after power restoration
<b>OUTPUT SETTINGS</b>	Float V setting	Adjust output voltage FLOAT VpC. Charger will deliver this voltage upon entering FLOAT mode. Adjustable from 2.00 - 2.45 VpC for flooded lead acid and VRLA batteries, 1.20 - 1.60 VpC for NiCd. May not be higher than equalize setting. Must be higher than Batt on disch alarm and V min. allowed DC bus by at least 2% nominal battery voltage.
	Equalize V setting	Adjust output voltage EQUALIZE VpC. Charger will deliver this voltage upon entering EQUALIZE mode. Adjustable from 2.00 - 2.45 VpC for flooded lead acid and VRLA batteries, 1.20 - 1.60 VpC for NiCd. May not be lower than float setting. Must be lower than High DC volt alarm setting by at least 2% nominal battery voltage.
	Current limit	Adjust current limit value from 33% to 110% of nominal current rating. Charger current limit is governed to this value.
<b>ALARM SETTINGS</b>  <i>(See Section 9.3 for alarm definitions)</i>	Bat end disch alarm	Adjust VpC setpoint to trigger Battery End-of-Discharge alarm. Adjustable from 1.70 - 2.20 VpC for flooded lead acid and VRLA batteries, 1.00 - 1.40 VpC for NiCd. May not be higher than Low DC volt alarm.
	Low DC volt alarm	Adjust VpC setpoint to trigger Low DC voltage alarm. Adjustable from 1.70 - 2.20 VpC for flooded lead acid and VRLA batteries, 1.00 - 1.40 VpC for NiCd.* May not be lower than Bat end disch alarm. May not be higher than Batt on disch alarm.
	Batt on disch alarm	Adjust VpC setpoint to trigger Battery Discharging alarm. Adjustable from 1.70 - 2.20 VpC for flooded lead acid and VRLA batteries, 1.00 - 1.40 VpC for NiCd.* Must be lower than Float V setting by at least 2% of nominal battery voltage. May not be lower than Low DC volt alarm.
	High DC volt alarm	Adjust VpC setpoint to trigger High DC voltage alarm. Adjustable from 2.20 - 2.50 VpC for flooded lead acid and VRLA batteries, 1.50 - 1.70 VpC for NiCd.* Must be higher than Equalize V setting by at least 2% of nominal battery voltage. May not be higher than Overvolt shutdown setting.

\*Settings for alarm voltages and over voltage shutdown contain an anti-collision feature that prevents false alarms and shutdown due to operator error. Adjustments are limited to maintain a 2% "guard band" between alarm trip points and the output set points.

Table continued on next page

Main Menus <i>(Press up and down arrows to scroll through Main Menu Options)</i>	Configurable/Viewable Parameters <i>(Press left and right arrows to scroll through choices within each Menu Option)</i>	Parameter Descriptions/Definitions																																										
ALARM SETTINGS <i>(cont.)</i>  <i>(See Section 9.3 for alarm definitions)</i>	Overvolt shutdown	Adjust VpC setpoint to trigger Over Voltage Shutdown alarm. Adjustable from 2.20 - 2.60 VpC for flooded lead acid and VRLA batteries, 1.50 - 1.75 VpC for NiCd.* May not be lower than High DC volt alarm setting.																																										
	Low current alarm	Adjust from 2% to 50% of nominal current setpoint to trigger Low Current alarm																																										
	Ground fault alarm sensitivity	<p>Enable or disable Ground Fault alarm. Select OFF to disable or select level of sensitivity for ground fault - HIGH, MED, or LOW. LOW sensitivity indicates alarm is hardest to trip, HIGH indicates alarm is most sensitive. Sensitivity is represented by resistance values, within +/- 30% tolerance, as shown in the following table:</p> <table border="1" data-bbox="748 604 1414 793"> <thead> <tr> <th></th> <th colspan="2">LOW</th> <th colspan="2">MED</th> <th colspan="2">HIGH</th> </tr> </thead> <tbody> <tr> <td>12 VDC</td> <td>3KΩ</td> <td>0.21mA</td> <td>10KΩ</td> <td>0.13mA</td> <td>30KΩ</td> <td>0.06mA</td> </tr> <tr> <td>24 VDC</td> <td>3KΩ</td> <td>0.41mA</td> <td>10KΩ</td> <td>0.25mA</td> <td>30KΩ</td> <td>0.11mA</td> </tr> <tr> <td>48 VDC</td> <td>10KΩ</td> <td>0.25mA</td> <td>30KΩ</td> <td>0.15mA</td> <td>100KΩ</td> <td>0.07mA</td> </tr> <tr> <td>120VDC</td> <td>10KΩ</td> <td>0.62mA</td> <td>30KΩ</td> <td>0.38mA</td> <td>100KΩ</td> <td>0.17mA</td> </tr> <tr> <td>240VDC</td> <td>20KΩ</td> <td>0.63mA</td> <td>60KΩ</td> <td>0.38mA</td> <td>200KΩ</td> <td>0.17mA</td> </tr> </tbody> </table>		LOW		MED		HIGH		12 VDC	3KΩ	0.21mA	10KΩ	0.13mA	30KΩ	0.06mA	24 VDC	3KΩ	0.41mA	10KΩ	0.25mA	30KΩ	0.11mA	48 VDC	10KΩ	0.25mA	30KΩ	0.15mA	100KΩ	0.07mA	120VDC	10KΩ	0.62mA	30KΩ	0.38mA	100KΩ	0.17mA	240VDC	20KΩ	0.63mA	60KΩ	0.38mA	200KΩ	0.17mA
		LOW		MED		HIGH																																						
12 VDC	3KΩ	0.21mA	10KΩ	0.13mA	30KΩ	0.06mA																																						
24 VDC	3KΩ	0.41mA	10KΩ	0.25mA	30KΩ	0.11mA																																						
48 VDC	10KΩ	0.25mA	30KΩ	0.15mA	100KΩ	0.07mA																																						
120VDC	10KΩ	0.62mA	30KΩ	0.38mA	100KΩ	0.17mA																																						
240VDC	20KΩ	0.63mA	60KΩ	0.38mA	200KΩ	0.17mA																																						
Seconds delay alarm relays	Adjust amount of time from 5 to 50 seconds to delay activation of alarm relay contacts after alarm event takes place.																																											
BATTERY CHECK	Periodic auto battery check	Set to ON or OFF. Charger will automatically engage a Battery Check test on a periodic interval configured by user.																																										
	Battery Check front panel button	Set to ON to allow user to engage Battery Check test from front panel BATT CHCK button. Set to OFF to disable use of button.																																										
	Days battery check interval	Adjust amount of time from 1 to 60 days between periodic Battery Check tests																																										
	Minutes batt. check duration	Adjust amount of time from 1 to 60 minutes to run Battery Check test																																										
	V min. allowed DC bus	Adjust VpC for minimum voltage allowed during Battery Check test. Adjustable from 1.80 - 2.06 VpC for flooded lead acid and VRLA batteries, 1.125 - 1.287 VpC for NiCd. Must be lower than Float V setting by at least 2% of nominal battery voltage.																																										
TEMPERATURE INFO	ambient temperature	Displays ambient temperature in °C and warnings about over and under charging the battery.																																										
UNIT SETUP	Battery temp. compensation	Set to ON or OFF. Temperature compensation of the charger output voltage may be implemented either locally or remotely. Chargers include local temperature compensation by default. Remote temperature compensation is offered via an optional external device located at the batteries. Temperature compensation is active between 0 and 40°C (see FIG 7). Temperature compensation will automatically scale back output voltage to prevent conflicts with high and low voltage alarm settings and Over Voltage Shutdown setting.																																										
	Temp comp slope	Adjust temperature compensation slope from 1.0 to -5.5mV/cell/°C for lead-acid batteries and 0.75 to -4.0mV/cell/°C for nickel-cadmium batteries. See FIG 7 for examples of slope selections.																																										
	Audio alarm indication <i>(available with version 3.00 or later firmware)</i>	Set to ON or MUTE. Activates or silences audible alarm indication.																																										
	Change battery/type <i>(available with version 3.00 or later firmware)</i>	Select type of battery to be charged - Flooded Lead-Acid, VRLA or Nickel-Cadmium (see Section 8.5)																																										

\*Settings for alarm voltages and over voltage shutdown contain an anti-collision feature that prevents false alarms and shutdown due to operator error. Adjustments are limited to maintain a 2% "guard band" between alarm trip points and the output set points.

Table continued on next page

Main Menus <i>(Press up and down arrows to scroll through Main Menu Options)</i>	Configurable/Viewable Parameters <i>(Press left and right arrows to scroll through choices within each Menu Option)</i>	Parameter Descriptions/Definitions																		
UNIT SETUP <i>(cont.)</i>	Battery cell count	Adjust number of series cells in battery string as follows: <table border="1" style="margin-left: auto; margin-right: auto;"> <thead> <tr> <th></th> <th>Nickel-Cadmium</th> <th>Flooded lead acid/VRLA</th> </tr> </thead> <tbody> <tr> <td>12V</td> <td>6 – 10</td> <td>4 – 6</td> </tr> <tr> <td>24V</td> <td>12 – 20</td> <td>8 – 12</td> </tr> <tr> <td>48V</td> <td>25 – 40</td> <td>16 – 24</td> </tr> <tr> <td>120V</td> <td>64 – 96</td> <td>40 – 60</td> </tr> <tr> <td>240V</td> <td>128 – 192</td> <td>80 – 120</td> </tr> </tbody> </table>		Nickel-Cadmium	Flooded lead acid/VRLA	12V	6 – 10	4 – 6	24V	12 – 20	8 – 12	48V	25 – 40	16 – 24	120V	64 – 96	40 – 60	240V	128 – 192	80 – 120
	Nickel-Cadmium	Flooded lead acid/VRLA																		
12V	6 – 10	4 – 6																		
24V	12 – 20	8 – 12																		
48V	25 – 40	16 – 24																		
120V	64 – 96	40 – 60																		
240V	128 – 192	80 – 120																		
VIEW UNIT INFO	Serial Number	Six digit serial number set at factory																		
	Software Revision	Software revision currently loaded in charger																		
	Build Date	Date charger was built																		
OTHER	User Interface Mode	Select User Interface Mode - Expert, Normal or Monitor Only (see Section 8.7)																		
	Remove/Install Black Box Data Recorder	To prevent data loss or corruption, the Black Box Data Recorder must be removed or installed only when this screen is displayed (see Section 10).																		
	Start EEPROM Test <i>(available with version 3.00 or later firmware)</i>	Scan all EEPROM pages to perform a CRC check for data errors. Press UP arrow to run test. Second line reports number of non-empty pages that fail CRC check. Contact SENS Customer Service if errors exist.																		
	Relay & Display Test <i>(available with version 3.00 or later firmware)</i>	Press UP arrow to set alarm relays to FAIL, LCD black, multi-color LEDs red, and single-color LEDs on. Press DOWN arrow to set relays to OK, LCD blank, multi-color LEDs green, and single-color LEDs off. A single button press will engage the test for two seconds. Holding the button will test continuously and for ten seconds after button release.																		

Figure 7: Two temperature compensation curve examples

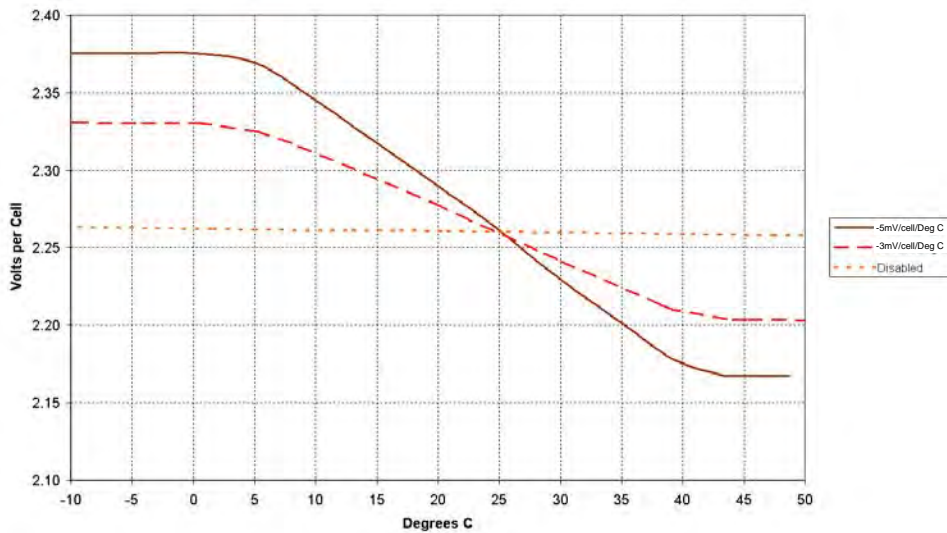

8.6.3 Adjustment Limits/Voltage Setting Interlocks

Figure 8: Charger Adjustment Limits for Flooded and VRLA Batteries

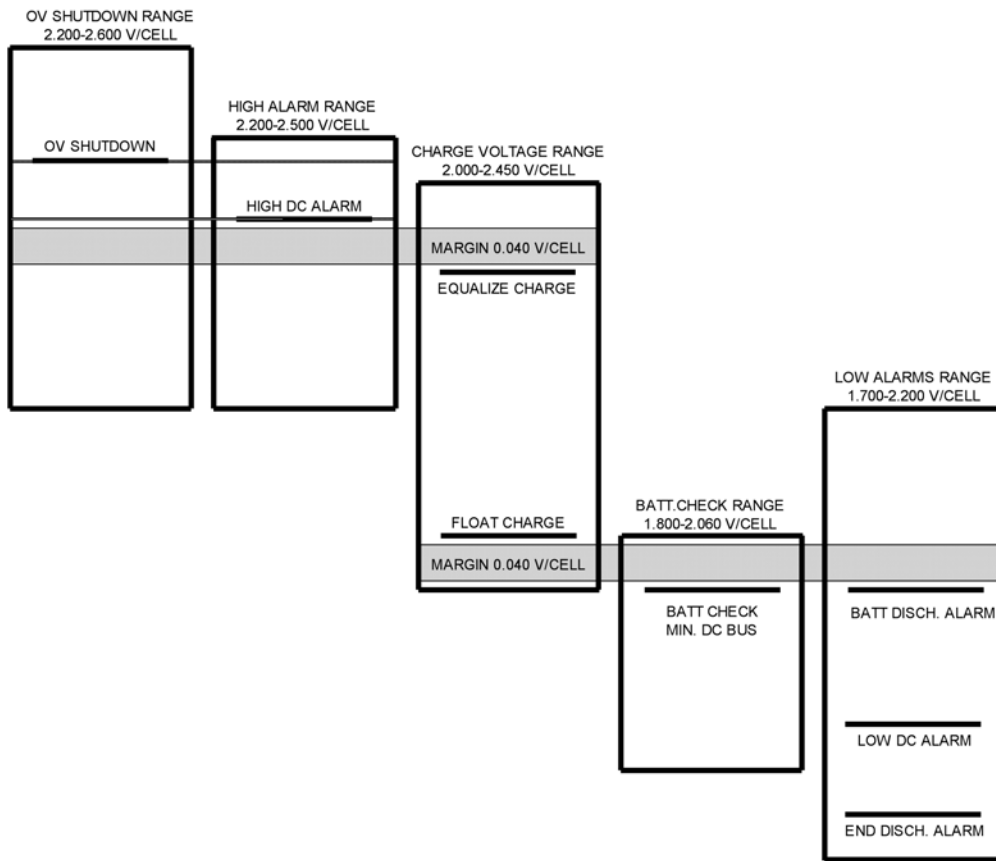
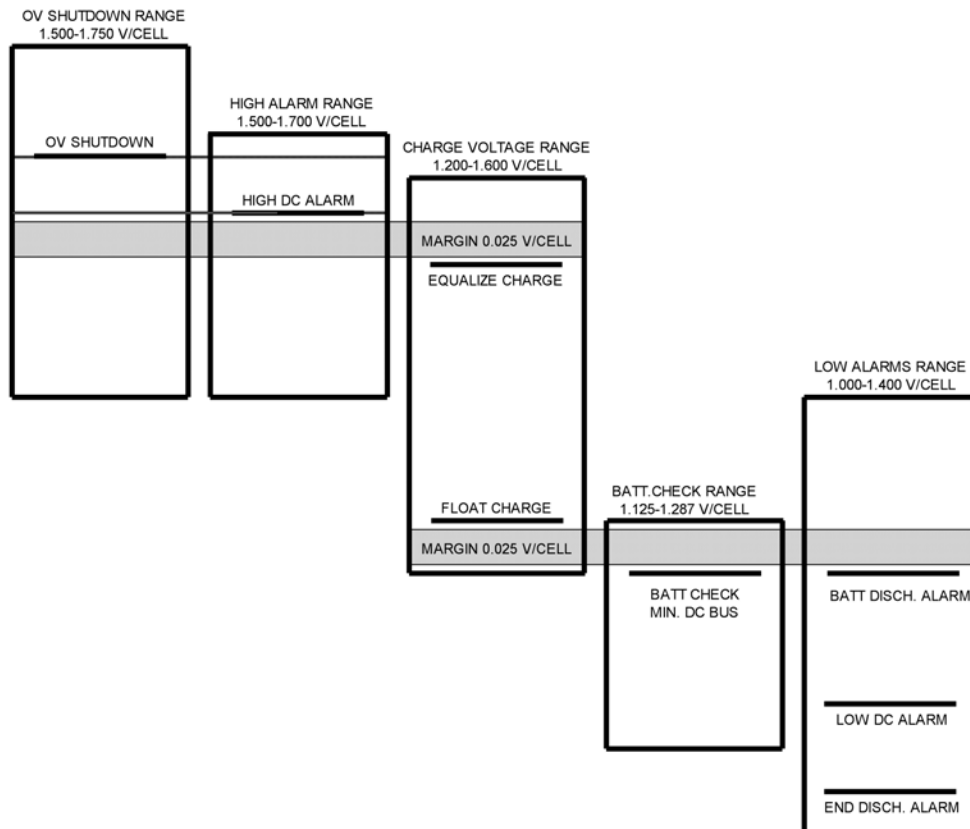

Figure 9: Charger Adjustment Limits for Nickel-Cadmium Batteries



## 8.7 User Interface Mode—Unlock/Lock Jumper

Three User Interface Modes are available to ensure that charger parameters are not mistakenly changed and are only configurable when desired. Move the unlock/lock jumper to the unlock position to change User Interface Mode. The unlock/lock jumper is only accessible by opening the charger front door. It is located on the Control Printed Circuit Board (see **FIG 10**). After the desired User Interface Mode is selected, put the unlock/lock jumper back into the lock position. The User Interface Mode cannot be changed again unless the jumper is placed in the unlock position. The three available User Interface Modes are Expert Mode, Normal Mode and Monitor Only Mode. See Section 8.6.2 to set desired mode.

### NOTE:

Regardless of the User Interface Mode selected, the Over Voltage Shutdown alarm setpoint, battery type, battery number of cells, commissioning, and audible alarm indication are only adjustable when the unlock/lock jumper is in the unlock position.

### 8.7.1 Expert Mode

Expert Mode allows full access to configurable charger parameters from the User Interface except the Over Voltage Shutdown alarm setpoint, battery type, battery number of cells, commissioning, and audible alarm indication (only adjustable if the unlock/lock jumper is placed in the unlock position).

### 8.7.2 Normal Mode

Normal Mode restricts access to configurable charger parameters from the User Interface. The user only has access to change the charge mode (float, manual equalize, automatic equalize), adjust manual equalize time, run the battery test, and silence an audible alarm.

### 8.7.3 Monitor Only Mode

Monitor Only mode prevents any front panel adjustment except silencing an audible alarm.

**Figure 10: Unlock/Lock Jumper**

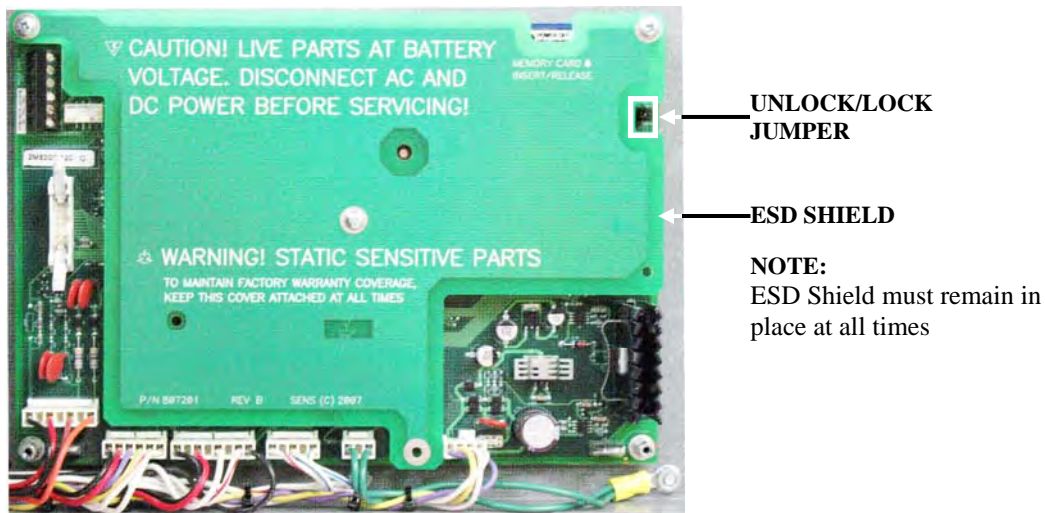

## 9 ALARMS

---

### 9.1 Summary Alarm Contact

The charger provides a ‘SUMMARY’ form C relay, which changes state if any alarm condition exists. The relay changes state a user-settable time period, ranging from 5 to 50 seconds (see Section 8.6.2), after the onset of a fault and is located on the Control Printed Circuit Board (see **FIG 3**). The ‘SUMMARY’ relay allows the user to monitor several alarms at once with one set of contacts. The ‘SUMMARY’ relay changes state as described in Section 9.3. See **TABLE 4** for alarm contact designations.

A ‘SUMMARY’ relay tripped by a Battery Check test failure is reset by pressing the front panel ENTER/BACK button twice or upon successfully passing a new Battery Check test.

### 9.2 Individual Relay Alarm Contacts—*Optional*

Two different individual alarm relay package options are available, only one of which can be installed at a time. The Standard Alarm Relay Printed Circuit Board offers five alarm discrete Form C contacts. The Extended Alarm Relay Printed Circuit Board offers seven discrete Form C contacts plus a pilot relay.

The form C relay contacts change state when alarms are activated (see **FIG 3**). The relay contacts change state a user-selectable time period after the onset of a fault. In the event of a second alarm, the delay will not start over. Instead, the second alarm relay will change state after the original alarm delay. The alarm relay contacts change state as described in Section 9.3. See **TABLE 4** for alarm contact designations.

The Extended Alarm Relay Printed Circuit Board also includes one pilot relay that automatically closes when the charger enters EQUALIZE mode, and opens when the charger reverts to FLOAT mode (see **FIG 3**). See Section 8.3.2 for more information on EQUALIZE mode.

When an optional Alarm Relay Printed Circuit Board is used the ‘SUMMARY’ alarm (located on Control Printed Circuit Board) continues to function. The charger includes two separate microprocessors, one in control of the ‘SUMMARY’ alarm and the other in control of the individual relays. Users are encouraged to connect both the ‘SUMMARY’ and individual relay alarms to provide redundant alarm notification.

### 9.3 Alarm Definitions

See Section 8.6.2 to adjust alarm settings. Alarms are displayed on the front panel LCD (see **FIG 4**) and often via LED and/or alarm relay contacts.

When Temperature Compensation is active, the DC output voltage is temperature compensated, however alarm threshold levels are not.

1. **BATTERY REVERSE POLARITY** - An audible alarm (beeping tone) indicates the battery is connected backwards. Disconnect the AC power source and correct the reverse polarity problem. Activates red DC SYSTEM ALARM LED, red BATT CHCK LED and red BATTERY LED. Summary relay changes to Fail state. These indications require AC power on. Silencing the audible alarm feature does not silence this alarm.
2. **LOW DC** - Indicates DC output voltage is below a programmed level. Activates red DC SYSTEM ALARM LED and yellow DC VOLTS LED. Summary relay changes to Fail state. Optional Alarm Relay Printed Circuit Board relay K6 changes to Fail state.
3. **HIGH DC** - Indicates DC output voltage is above a programmed level. Activates red DC SYSTEM ALARM LED and red DC VOLTS LED. Summary relay changes to Fail state. Optional Alarm Relay Printed Circuit Board relay K3 changes to Fail state.
4. **OVER VOLTAGE SHUTDOWN** - Indicates that the charger has executed a high voltage shutdown. Activates red CHARGER ALARM LED, red CHARGER LED and red DC VOLTS LED. Summary relay changes to Fail state. The charger disables itself whenever the output voltage exceeds the over voltage shutdown threshold and the charger is delivering current. Over Voltage Shutdown cannot be disabled, but is protected against nuisance trips. If over voltage is caused by an external source the charger will not execute an Over Voltage Shutdown. If an over voltage condition persists for 30 seconds, and the charger itself is the cause, the



charger will latch off. It remains off until AC power is shut down long enough to operate the AC Fail alarm relay, which resets the latched condition. This setting is prevented from being set less than the High DC alarm setting.

5. **DC BREAKER OPEN** - Indicates the DC breaker is open. Activates red CHARGER ALARM LED and red CHARGER LED. Summary relay changes to Fail state.
6. **CHARGER FAIL** - Indicates the charger is not providing the current demanded by the load. This is caused by an open DC output breaker or an internal component failure. Activates red CHARGER ALARM LED and red CHARGER DC BREAKER LED. Summary relay changes to Fail state. Optional Alarm Relay Printed Circuit Board relay K1 changes to Fail state.
7. **CHARGER OVER TEMPERATURE** - Indicates charger temperature is above designed operating temperature range. Activates yellow CHARGER LED. Will not activate the Summary relay.
8. **POSITIVE GROUND FAULT** - Indicates leakage current from the charger positive output to ground. Activates yellow DC SYSTEM ALARM LED. Summary relay changes to Fail state. Optional Alarm Relay Printed Circuit Board relay K4 changes to Fail state.
9. **NEGATIVE GROUND FAULT** - Indicates leakage current from the charger negative output to ground. Activates yellow DC SYSTEM ALARM LED. Summary relay changes to Fail state. Optional Alarm Relay Printed Circuit Board relay K4 changes to Fail state.
10. **BATTERY CHECK PASS/FAIL** - Indicates whether the Battery Check test passed or failed, meaning whether or not the battery supported the load (see Section 8.4). A failure activates red BATT CHCK LED, DC SYSTEM ALARM LED and red BATTERY LED. Summary relay changes to Fail state. Optional Alarm Relay Printed Circuit Board relay K5 changes to Fail state. Press the front panel ENTER/BACK button twice to remove/turn off a red BATT CHCK LED after a Battery Check failure. LED will remain blank until another Battery Check test is engaged. A tripped Battery Check relay, either Summary or individual relay, cannot be reset until a new Battery Check test successfully passes or until Battery Check is disabled. Upon a failure the audible alarm will sound for 25 seconds, however pressing the front panel ENTER/BACK key before the 25 second timeout will shut off the audible alarm.
11. **BATTERY END-OF-DISCHARGE** - Indicates battery should not be discharged any further and load should be dropped. Activates red DC SYSTEM ALARM LED and yellow DC VOLTS LED. Summary relay changes to Fail state. Optional Alarm Relay Printed Circuit Board relay K7 changes to Fail state.
12. **BATTERY DISCHARGING** - Indicates battery voltage is below a programmed level. Activates yellow DC SYSTEM ALARM LED. Will not activate the Summary relay.
13. **AC FAIL** - Indicates AC input voltage is not applied or is below 80% or above 110% of nominal line voltage. Activates red AC INPUT LED. Summary relay changes to Fail state. Optional Alarm Relay Printed Circuit Board relay K2 changes to Fail state.
14. **AC OUT-OF-SPEC** - Indicates AC input voltage is outside of suggested operating range. Low line alarm is triggered at 88% of nominal AC voltage for input codes "3" and "8" and at 84% for input codes "P", "T", "4", "S" and "V". High line alarm is triggered at 106% of nominal AC voltage for all models. Activates yellow AC INPUT LED. Will not activate the Summary relay.
15. **LOW CURRENT** - Indicates low output current being drawn from charger. Will not activate any LEDs or Summary relay.

## 10 BLACK BOX DATA RECORDER

Chargers equipped with the Black Box Data Recorder come with a memory card located on the Control Printed Circuit Board (see **FIG 11**). The Black Box Data Recorder keeps permanent record of DC voltages and currents, alarms, user adjustments, temperatures, battery check outcomes, input supply, and discharge durations.

Contact SENS (1-800-742-2326 or [www.sens-usa.com](http://www.sens-usa.com)) for assistance downloading and analyzing history data. User must document date and time Black Box Data Recorder is removed from charger to maintain accurate date and time for logged data.

### CAUTION:

To prevent data loss or corruption, the Black Box Data Recorder must be removed or installed by following the steps below.

#### 10.1 Procedure to remove/install Black Box Data Recorder

1. Using the User Interface Display menus, scroll down to the OTHERS menu.
2. Once at the OTHERS menu, scroll right to “Remove/Install Black Box Data Recorder”
3. It is now safe to remove or install the Black Box Data Recorder
4. If removing Black Box Data Recorder, record the date and time
5. Press ENTER/BACK to return to the main menu

**Figure 11: Black Box Data Recorder**

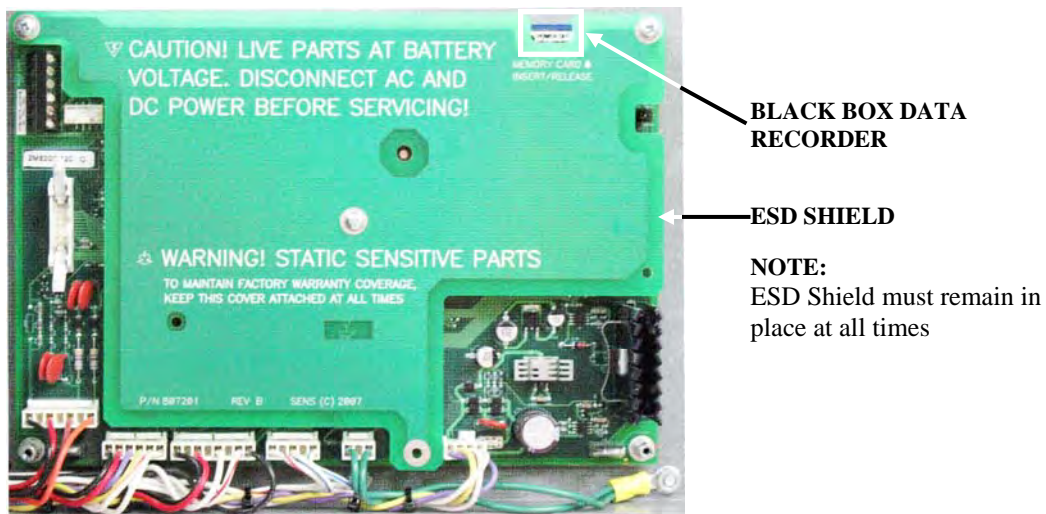

## 11 TYPICAL SETTINGS

### 11.1 Typical Battery Settings

Factory settings for float and equalize voltages and alarm settings for the most common battery configurations are shown for reference in **Tables 7, 8 and 9**. See the test data sheet provided with your charger for actual values.

**Table 7: Non-temperature compensated factory charger output DC voltage and alarm threshold settings for typical VRLA batteries**

Setting	Volts per Cell	12V, 6 Cells	24V, 12 Cells	48V, 24 Cells	110V, 55 Cells	120V, 60 Cells	220V, 110 Cells	240V, 120 Cells
Float Voltage	2.27	13.62	27.24	54.45	124.8	136.2	249.6	272.4
Equalize Voltage	2.30	13.80	27.60	55.20	126.5	138.0	253.0	276.0
Battery End-of-Discharge Threshold	1.75	10.50	21.00	42.00	96.2	105.0	192.4	210.0
Low DC Alarm Threshold	1.83	10.99	21.98	43.95	100.8	109.9	201.6	219.8
High DC Alarm Threshold	2.44	14.64	29.28	58.55	134.2	146.4	268.4	292.8
Over Voltage Shutdown Threshold	2.53	15.18	30.36	60.70	139.1	151.8	278.2	303.6

**Table 8: Non-temperature compensated factory charger output DC voltage and alarm threshold settings for flooded lead acid batteries**

Setting	Volts per Cell	12V, 6 Cells	24V, 12 Cells	48V, 24 Cells	110V, 55 Cells	120V, 60 Cells	220V, 110 Cells	240V, 120 Cells
Float Voltage	2.22	13.32	26.64	53.25	122.1	133.2	244.2	266.4
Equalize Voltage	2.30	13.80	27.60	55.20	126.5	138.0	253.0	276.0
Battery End-of-Discharge Threshold	1.75	10.50	21.00	42.00	96.20	105.0	192.4	210.0
Low DC Alarm Threshold	1.83	10.99	21.98	43.95	100.8	109.9	201.6	219.8
High DC Alarm Threshold	2.47	14.82	29.64	59.25	135.8	148.2	271.6	296.4
Over Voltage Shutdown Threshold	2.56	15.36	30.72	61.40	140.8	153.6	281.6	307.2

**Table 9: Non-temperature compensated factory charger output DC voltage and alarm threshold settings for NiCd batteries**

Setting	Volts per Cell	9 Cells	10 Cells	19 Cells	20 Cells	37 Cells	38 Cells	92 Cells	93 Cells	184 Cells	186 Cells
Float Voltage	1.43	12.87	14.30	27.16	28.60	52.90	54.30	131.5	132.9	263.0	265.8
Equalize Voltage	1.60	14.40	16.00	30.40	32.00	59.20	60.80	147.2	148.8	294.4	297.6
Battery End-of-Discharge Threshold	1.05	9.45	10.50	19.94	21.00	38.85	39.90	96.6	97.6	193.2	195.2
Low DC Alarm Threshold	1.10	9.90	11.00	20.90	22.00	40.70	41.80	101.2	102.3	202.4	204.6
High DC Alarm Threshold	1.65	14.85	16.50	31.34	33.00	61.05	62.70	151.8	153.4	303.6	306.8
Over Voltage Shutdown Threshold	1.68	15.12	16.80	31.92	33.60	62.15	63.80	154.5	156.2	309.0	312.4

## 12 MAINTENANCE AND TROUBLESHOOTING

---

**WARNING:**  
**CHARGER CONTROL CIRCUITS ARE AT BATTERY POTENTIAL AND CAN BE HAZARDOUS IF TOUCHED. ONLY INSULATED TOOLS SHOULD BE USED WHILE WORKING ON A CHARGER THAT IS POWERED UP. AVOID TOUCHING ANY CIRCUIT OR ANY BARE METAL.**

If you suspect there is a problem with the charger, the following should be done immediately:

- A. Disconnect AC mains supply.
- B. Open both AC input and DC output circuit breakers.
- C. Open the front door of the charger and inspect the interior for loose objects.
- D. Examine connector locations on printed circuit board for loose or un-plugged connectors.
- E. Reconnect AC mains supply.
- F. Check AC input voltage on line side of input breaker with an external voltmeter and verify it is in the proper range.
- G. Check wiring to DC output breaker and verify proper polarity of output connections. Also verify small terminals connected to load side of DC output breaker are still connected.

If none of these inspections yield a solution, consult **FIGS 12-19** for additional troubleshooting tips.

Figure 12: Troubleshooting chart for repeated AC breaker trip

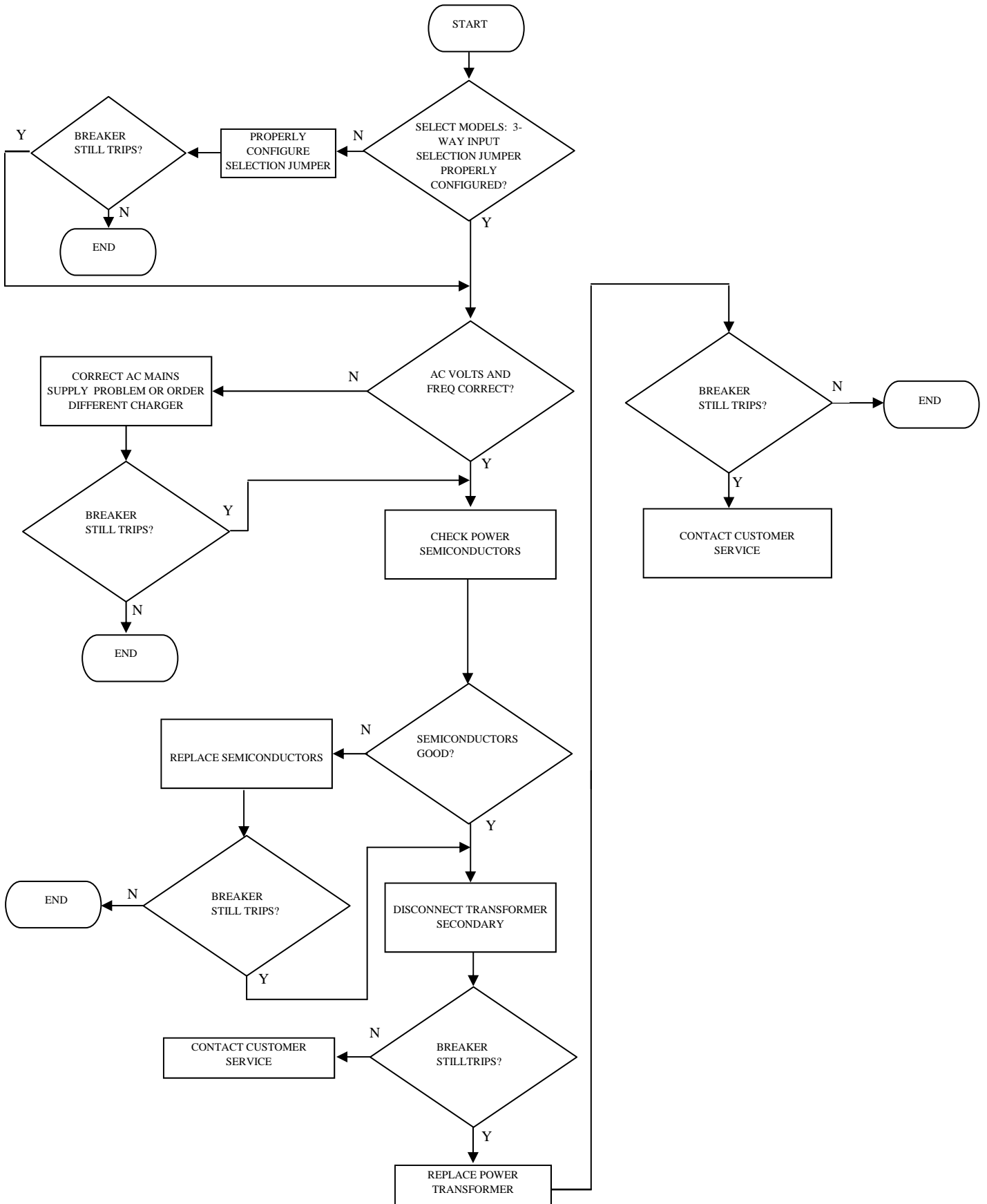

Figure 13: Troubleshooting flowchart for AC FAIL alarm indication

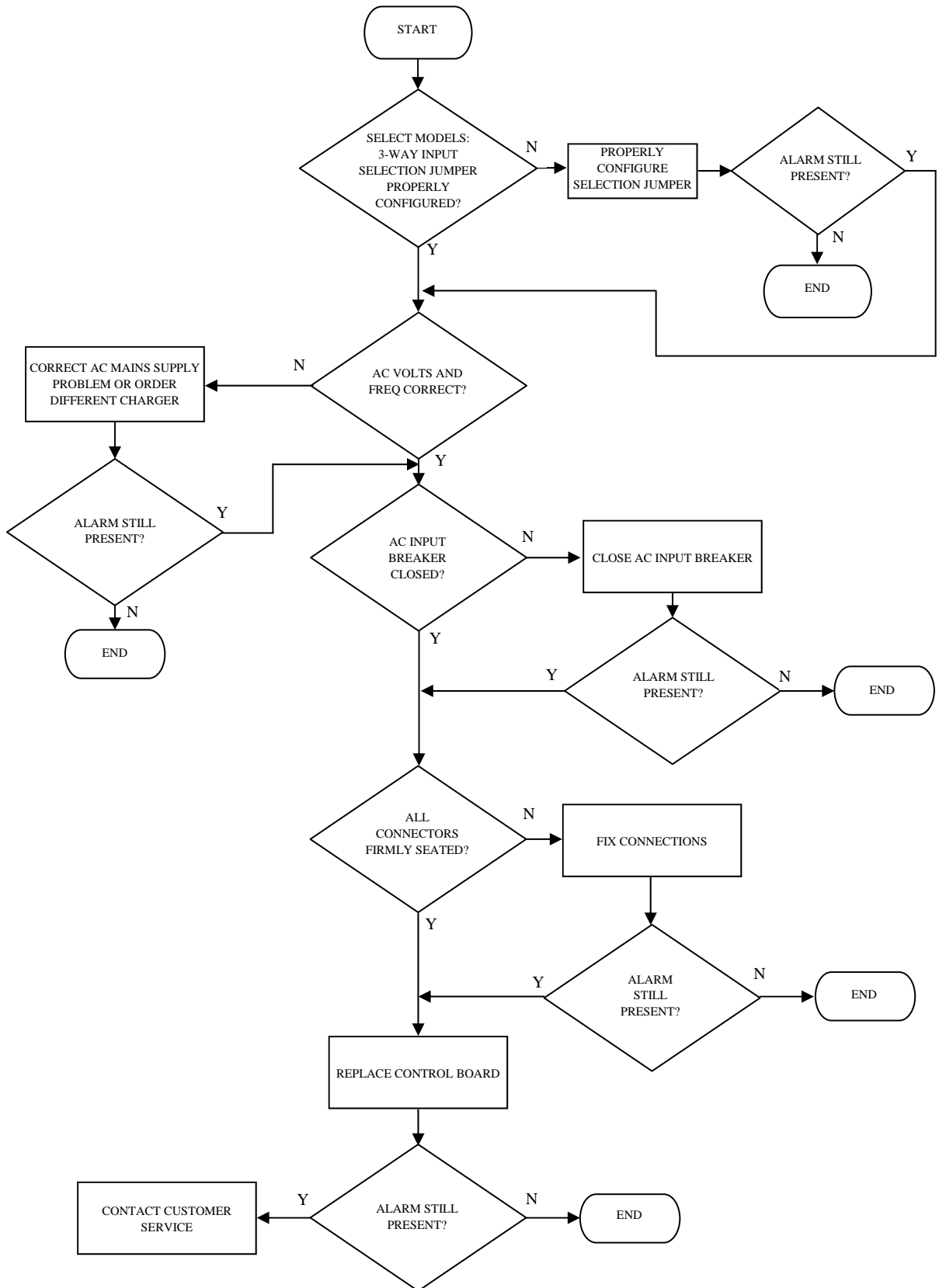

Figure 14: Troubleshooting flowchart for CHARGE FAIL alarm

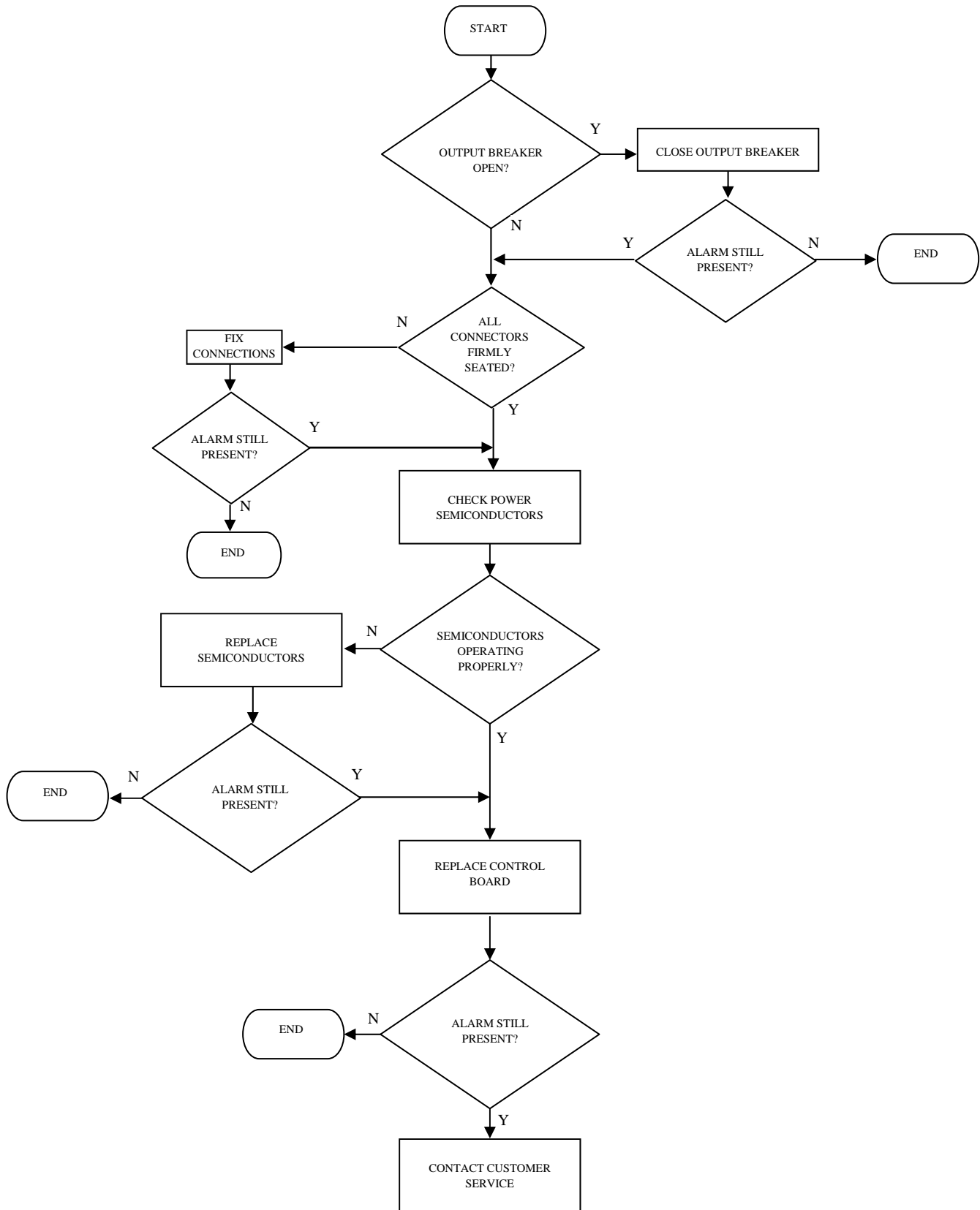

Figure 15: Troubleshooting flowchart for DC output breaker trip

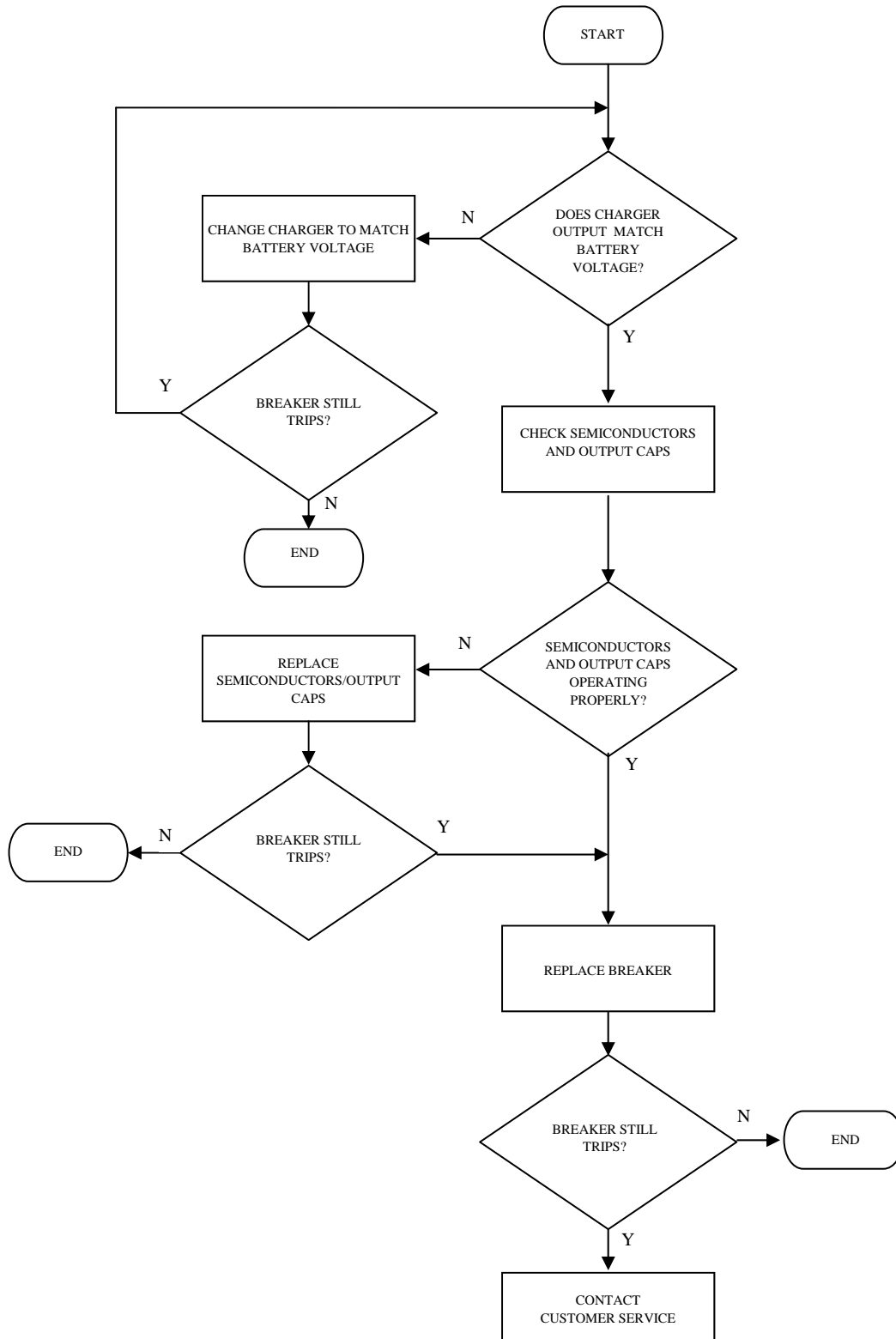



Figure 16: Troubleshooting flowchart for HIGH DC or OVER VOLTAGE SHUTDOWN

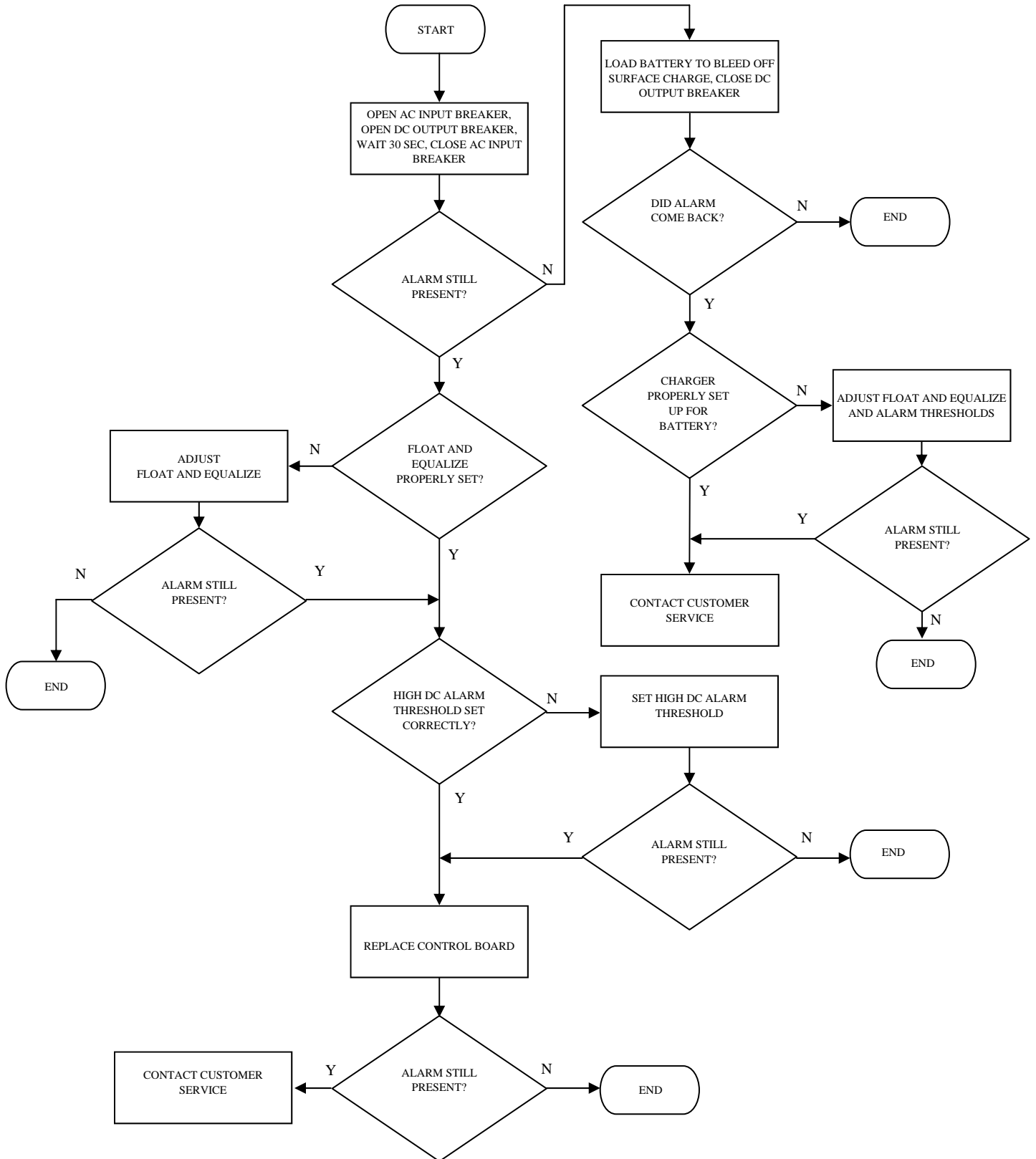

Figure 17: Troubleshooting flowchart for LOW DC alarm

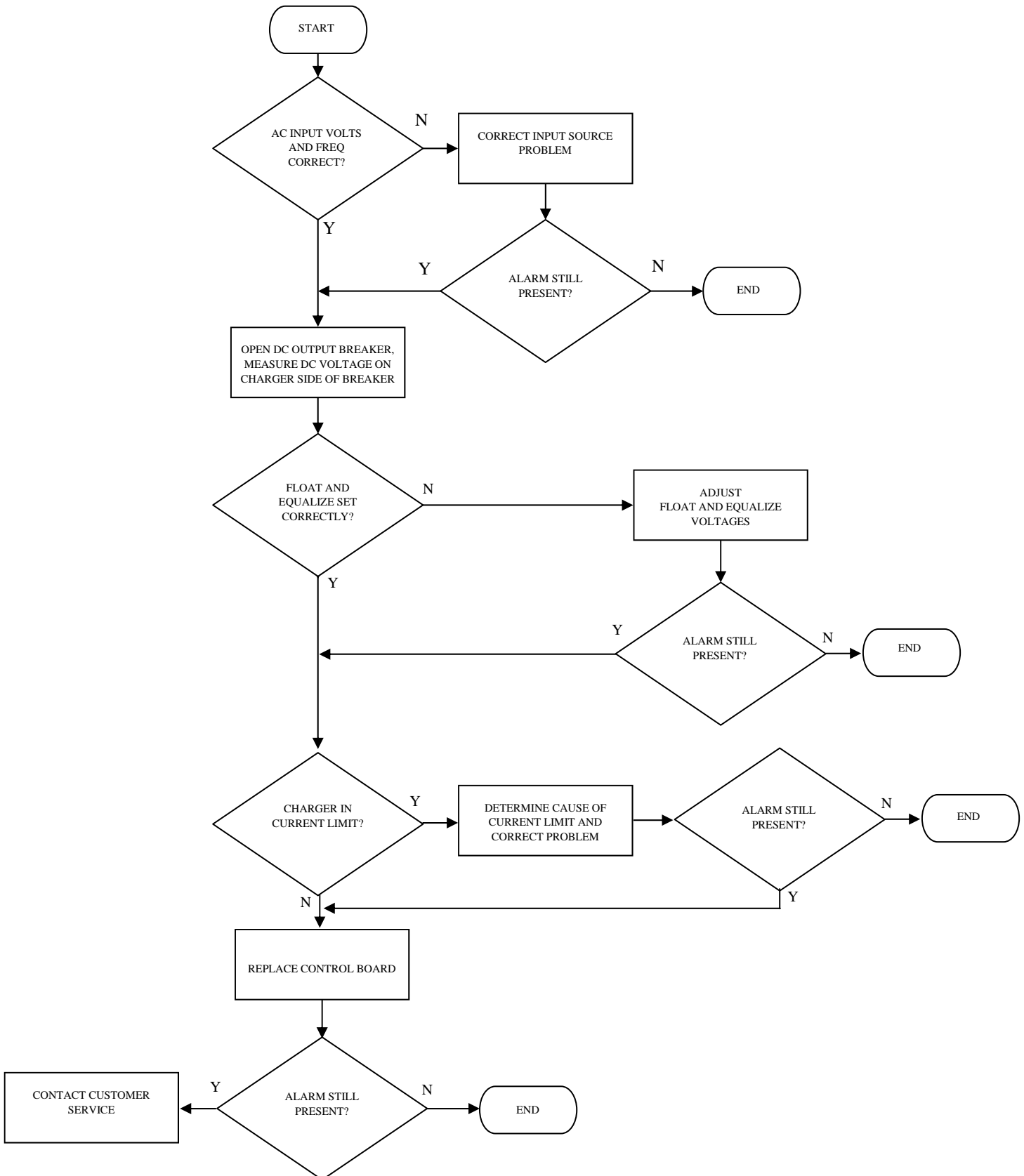

Figure 18: Troubleshooting flowchart for no output

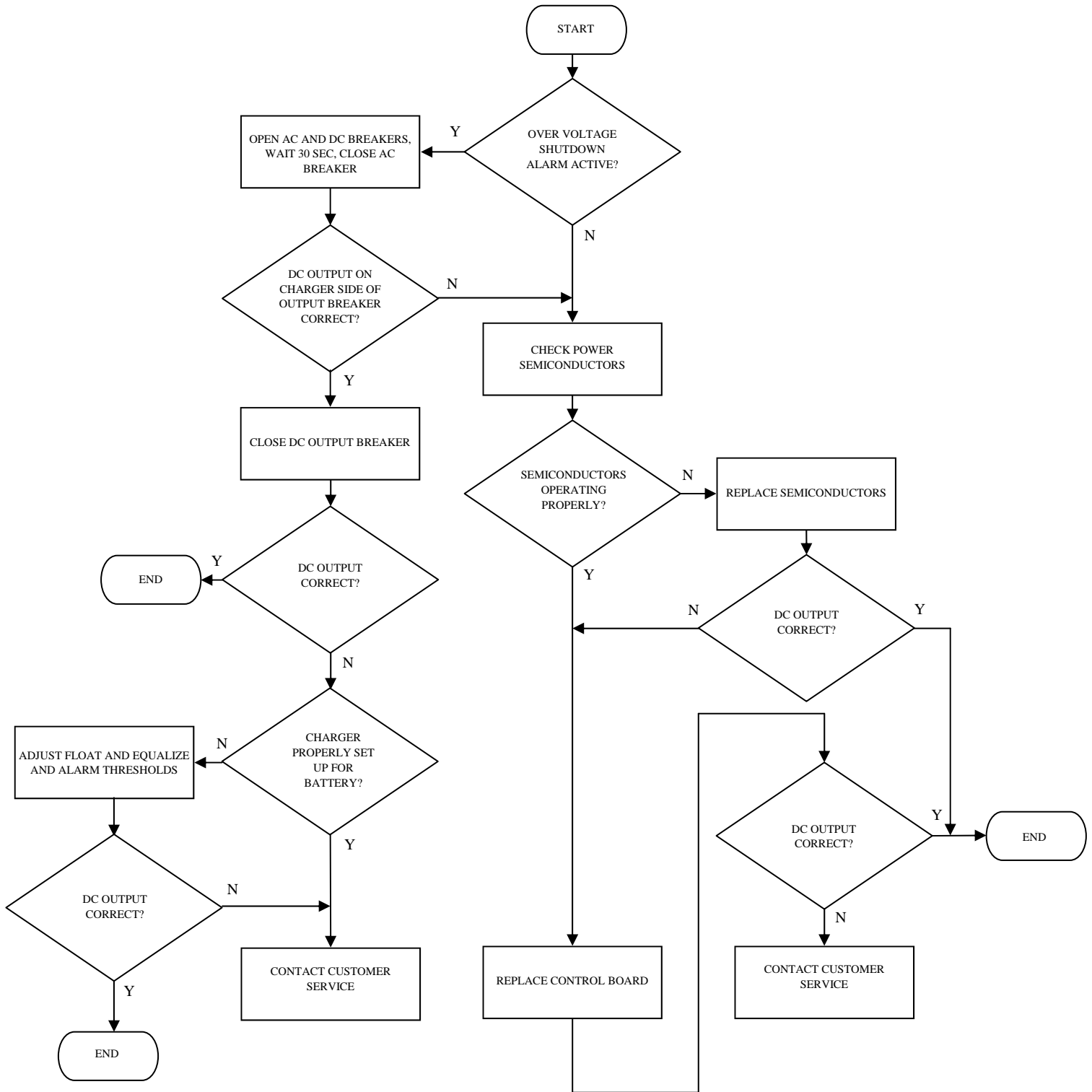
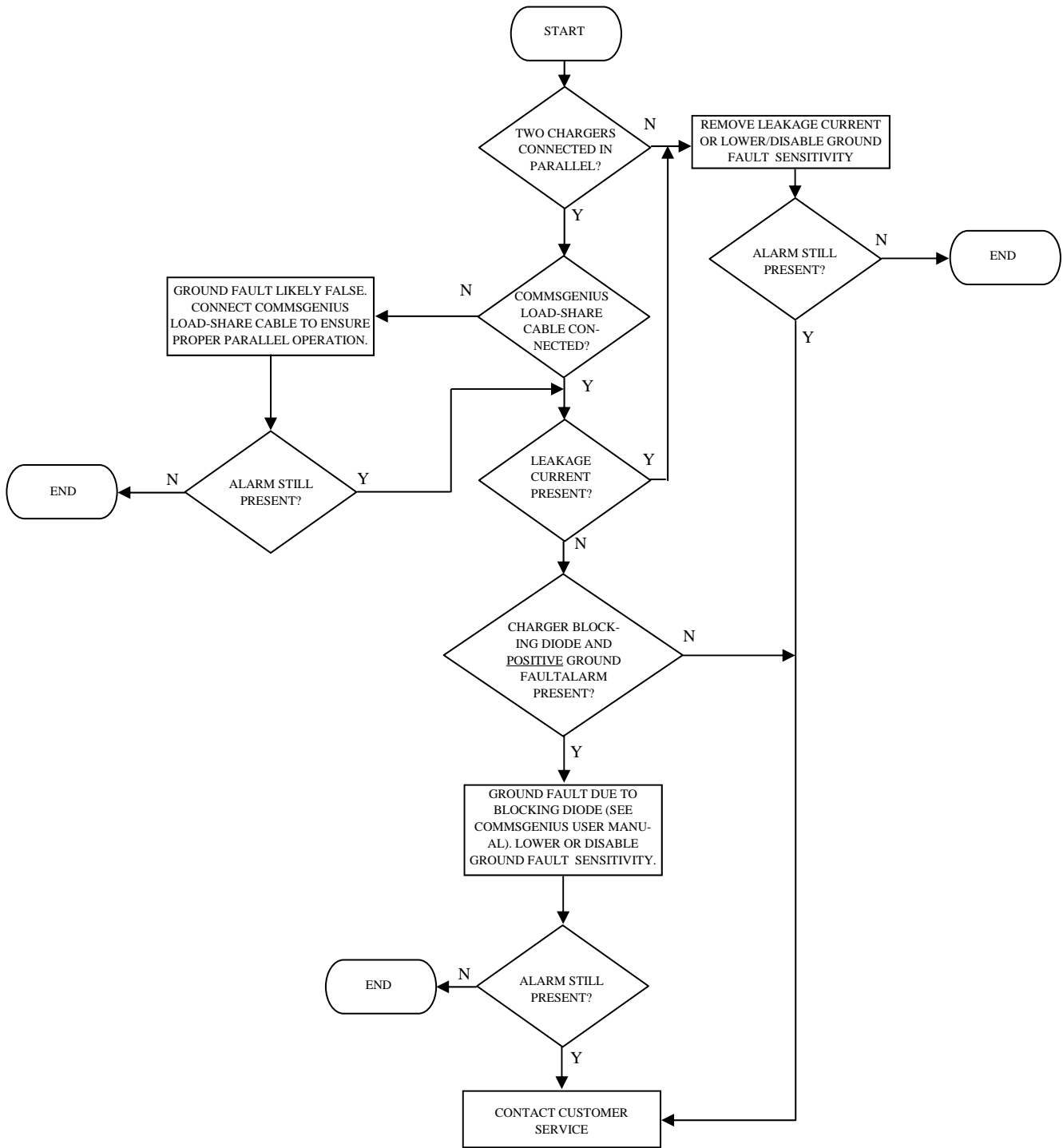
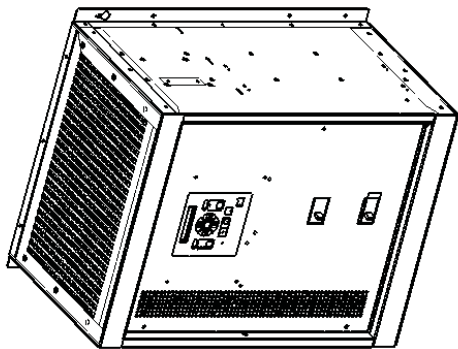
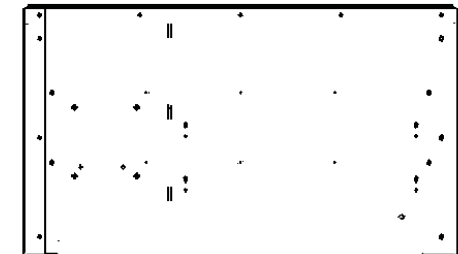
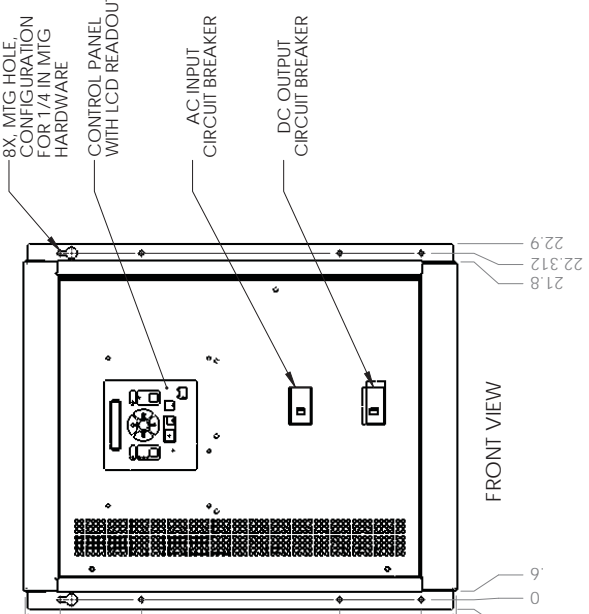
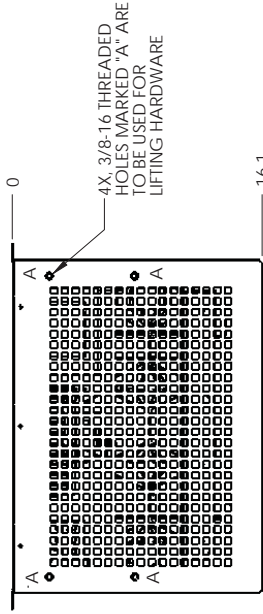

Figure 19: Troubleshooting flowchart for GROUND FAULT alarm



REVISIONS		DATE	APPROVED
DCN#	REV	DESCRIPTION	
105291	A	PRODUCTION RELEASE	11/9/06 GES
105432	B	SEE REDLINE IN DCN	8/23/07 GES
105474	C	ADDED SHT 3 OF 3, RACK MFG CONFIG.	11/8/07 GES



TOP VIEW

FRONT VIEW

RIGHT SIDE VIEW

ISO VIEW

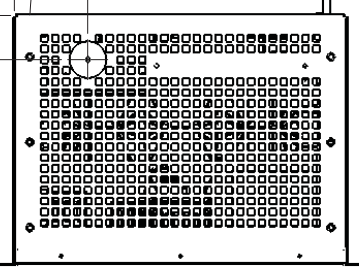
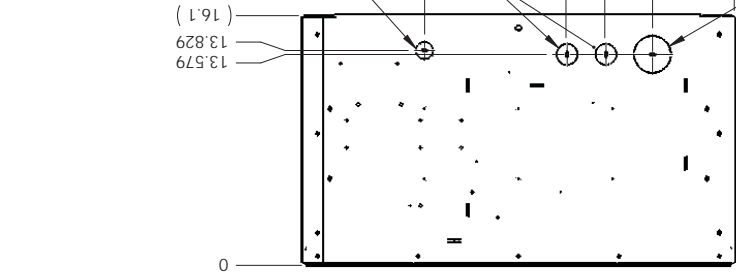

**WALL MOUNTING CONFIGURATION**

ALL DIMENSIONS ARE FOR REFERENCE ONLY UNLESS OTHERWISE SPECIFIED. DIMENSIONS ARE SUBJECT TO CHANGE

UNLESS OTHERWISE SPECIFIED:	NAME	DATE	REV
DIMENSIONS ARE IN INCHES	GES	11/09/06	
FRACTIONAL TOLERANCES:	DRAWN		
ANGULAR: MACH ± .1°	CHECKED		
THREE PLACE DECIMAL ± .005	ENG APPR		
	MFG APPR		
INTERPRET GEOMETRIC TOLERANCING PER:	Q.A.		
MATERIAL:	COMMENTS:		
FINISH:			
USED ON:			
APPLICATION:			
DO NOT SCALE DRAWING			

<b>STI</b>	<b>SENS</b>	<b>STORED ENERGY SYSTEMS</b>
TITLE: <b>ENERGENIUS IQ-2</b>		
23" CABINET		
MOUNTING CONFIG		
SIZE	DWG. NO.	REV
<b>B</b>	<b>DIA\00564</b>	<b>C</b>
SCALE: NONE	CAD FILE: DIA_00564.C	SHEET 1 OF 3

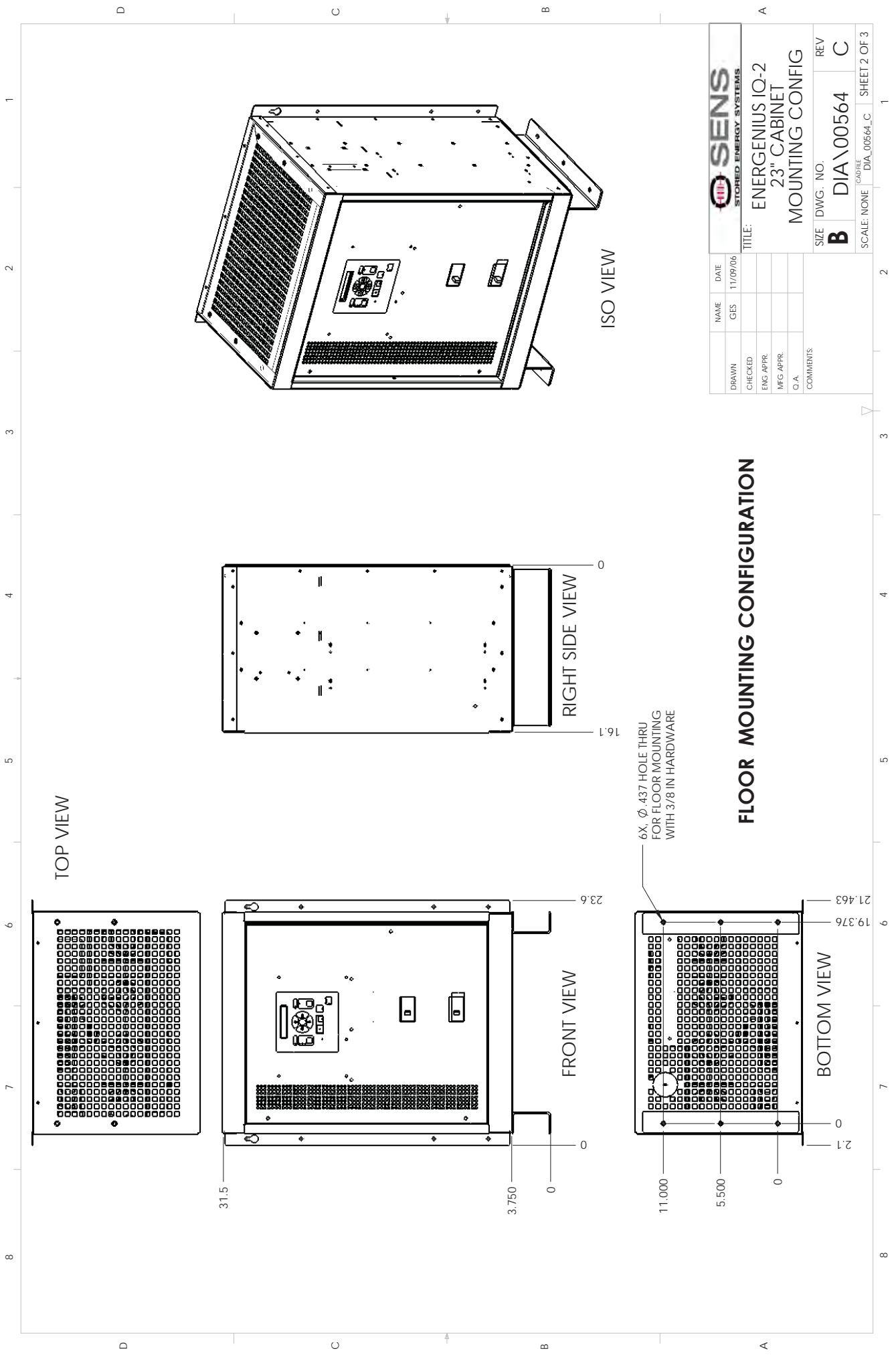

SENS STORED ENERGY SYSTEMS		NAME	DATE
DRAWN	GES	11/09/06	
CHECKED			
ENG APPR			
MFG APPR			
O.A.			
COMMENTS:			
TITLE:		SIZE	REV
ENERGENIUS IQ-2 23" CABINET MOUNTING CONFIG		<b>B</b>	<b>C</b>
SCALE: NONE		DIA\00564	
SCALE: NONE		DIA_00564_C	
SCALE: NONE		SHEET 2 OF 3	

### FLOOR MOUNTING CONFIGURATION

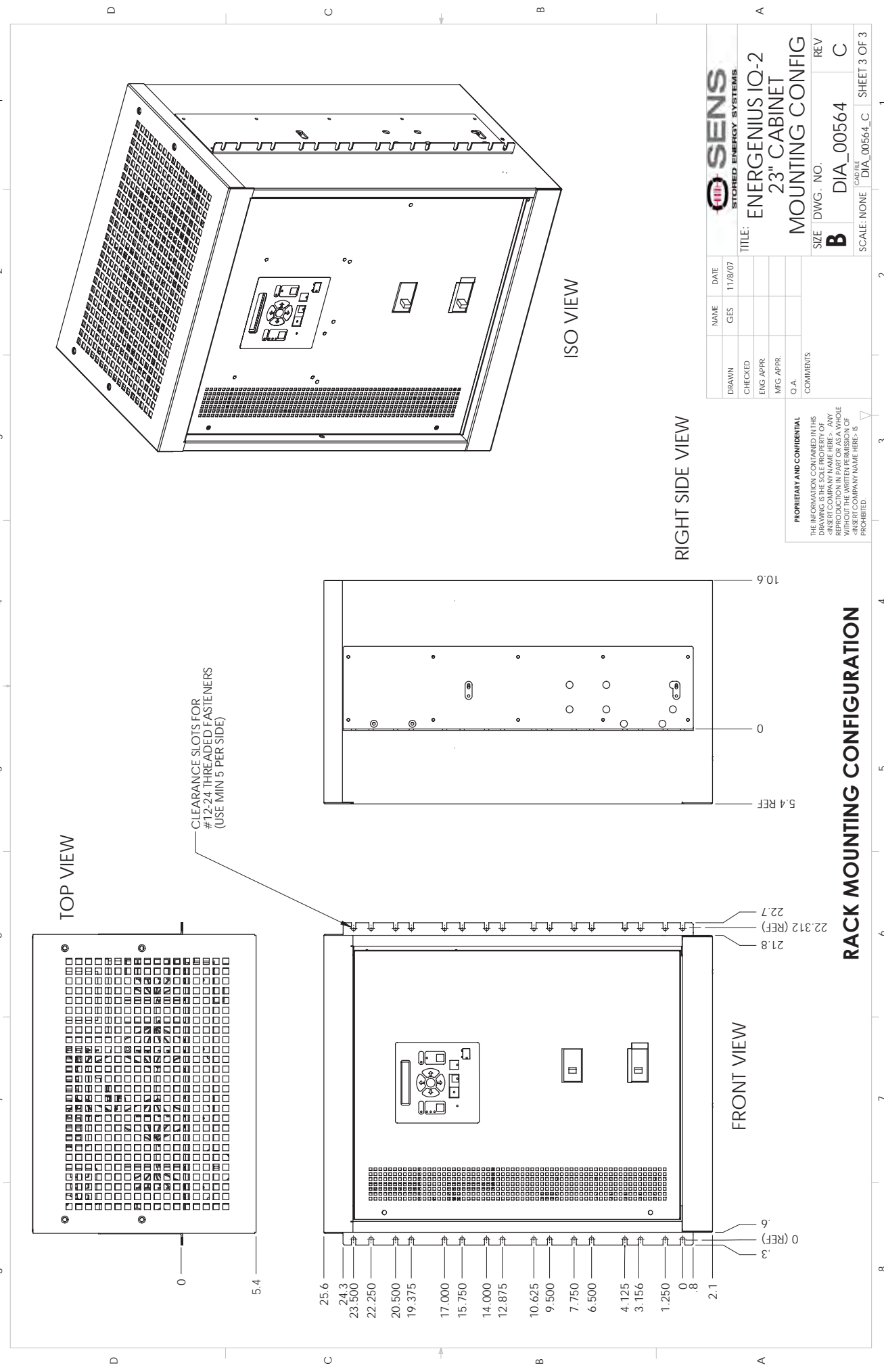

TOP VIEW

CLEARANCE SLOTS FOR #12-2.4 THREADED FASTENERS (USE MIN 5 PER SIDE)

ISO VIEW

RIGHT SIDE VIEW

FRONT VIEW

		<b>ENERGENIUS IQ-2</b> <b>23" CABINET</b> <b>MOUNTING CONFIG</b>	TITLE:
DRAWN: GES	DATE: 11/8/07	SIZE: DWG. NO. <b>B</b>	REV: <b>C</b>
CHECKED:	ENG APPR:	DIA: 00564	SCALE: NONE
MFG APPR:	COMMENTS:	DIA: 00564_C	SHEET 3 OF 3
O.A.	PROPRIETARY AND CONFIDENTIAL	THE INFORMATION CONTAINED IN THIS DRAWING IS THE PROPERTY OF SENS. ANY REPRODUCTION IN PART OR AS A WHOLE WITHOUT THE WRITTEN PERMISSION OF SENS COMPANY NAME HERE IS PROHIBITED.	

**RACK MOUNTING CONFIGURATION**

REVISIONS		DCN	REV	DESCRIPTION	DATE	APPROVED
		PLC-IO	A	Initial release.	1/11/07	GES
		105432	B	See redlines in DCN	8/23/07	GES
		105463	C	See redlines for revisions	10/12/07	GES
		106090	D	Add dual input terminal block (B-1), add 7" input columns for dual (D-2, D-3), terminal drawing.	1/17/2012	BWE

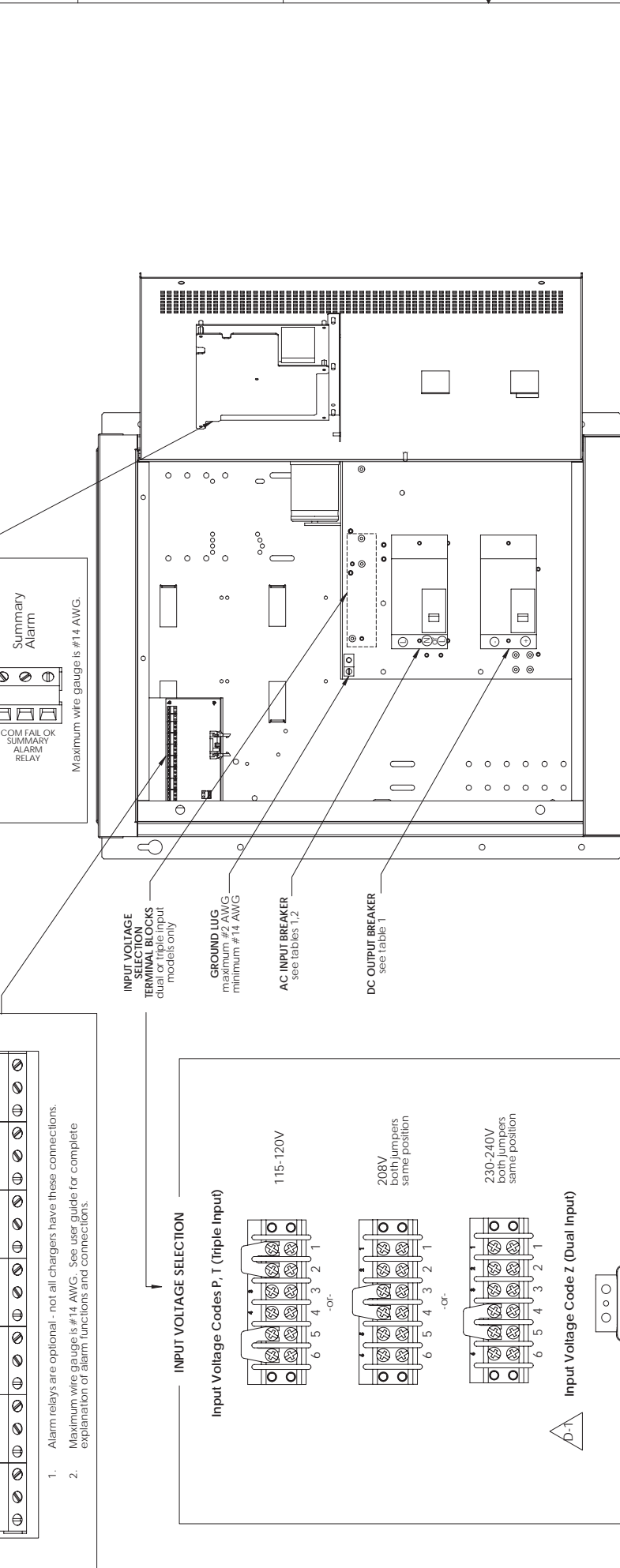
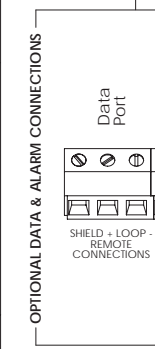

**Table 1 - AC Input Current and AC/DC Circuit Breaker Current Ratings**

Charger Model	Rated AC Input Current				Charger Input Breaker Current Ratings				Output Breaker Ratings				
	208V (3)	230/240V 50/60 Hz (4) 60 Hz (8)	120/208/240V 50/60 Hz (P) 60 Hz (1)	400V 50/60 Hz (V)	208V (3)	208/240V 60Hz (Z)	230/240V 50/60Hz (4) 60 Hz (8)	120/208/240V 50/60Hz (P) 60 Hz (1)		400V 50/60 Hz (V)			
C012-075	N/A	N/A	4.6	18/11/9.1	5.5	N/A	N/A	15	25	15	N/A	100	
C012-100	N/A	N/A	6.1	24/14/12	7.3	N/A	N/A	15	30	15	N/A	125	
C012-150	N/A	N/A	9.0	36/21/18	11	N/A	N/A	15	45	15	N/A	200	
C024-075	N/A	N/A	8.3	33/19/17	9.9	N/A	N/A	15	45	15	N/A	100	
C024-100	N/A	N/A	11	44/25/22	13	N/A	N/A	15	60	20	N/A	125	
C024-150	37	32	16	N/A	19	37	50	40	20	N/A	25	50	200
C048-075	34	30	15	N/A	18	34	45	40	20	N/A	25	45	100
C048-100	45	39	20	N/A	24	45	60	50	25	N/A	30	60	125
O120-035	38	33	17	N/A	20	38	50	45	25	N/A	25	50	45
O120-050	54	46	23	N/A	28	54	70	60	30	N/A	35	70	70
O240-016	35	30	15	N/A	18	35	45	40	20	N/A	25	45	20
O240-025	54	46	23	N/A	28	54	70	60	30	N/A	35	70	35

**Table 2 - AC Input Wire Gauge Ratings**

Rated Charger Input	Wire Gauge	
	Min	Max
≤ 240 VAC, 60 Hz	#14 Cu or Al	#2 Cu or Al
≤ 240 VAC, 50/60 Hz	#14 Cu, #12 Al	#10 Cu or Al
>240 VAC	#14 Cu, #12 Al	#10 Cu or Al
all 65 KAIC breakers (special order)	#14 Cu, #12 Al	#10 Cu or Al

**IMPORTANT INFORMATION**

- Some non-referenced items omitted for clarity.
- Style and size of AC and DC breakers may change depending on charger model number.

**NOTES TO INSTALLER**

- Make AC and DC connections direct to AC and DC breakers. Location of breakers is shown.
- Make connections to charger and terminal blocks per user guide instructions.

**SENS STORED ENERGY SYSTEMS**  
PROFESSIONAL AND COMMERCIAL

UNLESS OTHERWISE SPECIFIED:  
DIMENSIONS ARE IN INCHES  
DEF. VAL. TOLERANCES:  
ANGLES ± 1°  
TWO PLACE DECIMAL ± .02  
THREE PLACE DECIMAL ± .005  
DO NOT SCALE DRAWING

PER ASME Y14.5-2009

**DIAGRAM, ALM & CKT BRKR CONNECTIONS, O2**

DESCRIPTION: **DIAGRAM, ALM & CKT BRKR CONNECTIONS, O2**

DATE: 1/15/2012

NAME: BWE

DCN: 106090

REV: D

SIZE: C

DOCUMENT NUMBER: DIA\00569

REVISION: D

SHEET 1 OF 1





## ***Confirmation of Product Type Approval***

Please refer to the "Service Restrictions" shown below to determine if Unit Certification is required for this product. This certificate reflects the information on the product in the ABS Records as of the date and time the certificate is printed.

Pursuant to the Rules of the American Bureau of Shipping (ABS), the manufacturer of the below listed product held a valid Manufacturing Assessment (MA) with expiration date of 30/MAY/2018. The continued validity of the Manufacturing Assessment is dependent on completion of satisfactory audits as required by the ABS Rules.

And; a Product Design Assessment (PDA) valid until 02/MAY/2018 subject to continued compliance with the Rules or standards used in the evaluation of the product.

The above entitle the product to be called Product Type Approved.

The Product Design Assessment is valid for products intended for use on ABS classed vessels, MODUs or facilities which are in existence or under contract for construction on the date of the ABS Rules used to evaluate the Product.

ABS makes no representations regarding Type Approval of the Product for use on vessels, MODUs or facilities built after the date of the ABS Rules used for this evaluation.

Due to wide variety of specifications used in the products ABS has evaluated for Type Approval, it is part of our contract that; whether the standard is an ABS Rule or a non-ABS Rule, the Client has full responsibility for continued compliance with the standard.

**Product Name: Battery Charger**  
**Model Name(s): EnerGenius IQ**

**Presented to:**

STORED ENERGY SYSTEMS, LLC  
1840 INDUSTRIAL CIRCLE  
LONGMONT  
United States

**Intended Service:**

Charging of stationary batteries while providing clean stable DC power for continuous loads in Marine and Offshore Applications.

**Description:**

Automatic DC Power Supply / Charger with Intelligent Battery Monitoring & Data Logging. Model QXXXYYYAZZZZZZ Where XXX = DC output voltage Options: 012, 024, 048, 120, 240 Where YYY = DC output current Options: 006, 012, 016, 025, 035, 050, 075, 100, 150 Where A = AC input voltage Options: 3 = 208V, 60 Hz 4 = 230-240V, 50/60 Hz 8 = 480V, 60 Hz P = 115-120/208/230-240V, 50/60 Hz S = 230-240V, 60 Hz T = 115-120/208/230-240V, 60 Hz V = 400V, 50/60 Hz Z = 208/240V, 60 Hz Where Z = single digit option codes

**Ratings:**

Output Voltage: 12, 24, 48, 120/240 VDC Nominal Frequency: 50/60 Hz Operating Temperature: -40°C to + 50°C Enclosure: IP 22

**Service Restrictions:**

Unit Certification is not required for this product except where used for essential or emergency services as defined by 4-8-3/5.11.1(a) of the Rules. Suitable for non-hazardous locations.

**Comments:**

1. The Manufacturer has provided a declaration about the control of, or the lack of Asbestos in this product. 2. The charging facilities are to be such that a completely discharged battery is recharged to at least 80% capacity in not more than 10 hours. 3. Each user must use output cables that have sufficient current carrying capacity as per ABS Rules 4-8-2/7.7.1.

**Notes / Documentation:** Supporting Data: \* Doc: PRODSPEC- 135, Rev. K, Sync with: Eng. Rev. C, DCN 106267, EnerGenius I/Q Utility Grade Charger and Battery Check System, dated 4 April, 2013, 20 Pages; \* SENS IPX2 Q1 and Q2 Enclosure Drip Test; Cascade TEK Test Report Number: CTC C662 Dated May 22, 2013.

**Term of Validity:** This Product Design Assessment (PDA) Certificate 13-HS1014518-1-PDA, dated 03/May/2013 remains valid until 02/May/2018 or until the Rules or specifications used in the assessment are revised (whichever occurs first). This PDA is intended for a product to be installed on an ABS classed vessel, MODU or facility which is in existence or under contract for construction on the date of the ABS Rules or specifications used to evaluate the Product. Use of the Product on an ABS classed vessel, MODU or facility which is contracted after the validity date of the ABS Rules and specifications used to evaluate the Product, will require re-evaluation of the PDA. Use of the Product for non ABS classed vessels, MODUs or facilities is to be to an agreement between the manufacturer and intended client.

**ABS Rules:** 2013 Steel Vessels Rules 1-1-4/7.7, 1-1-A3, 4-8-1/7.3.3, 4-8-3/5.1, 4-8-3/5.3, 4-8-3/5.9 & 4-8-3/5.11 2012 MODU Rules 4-3-1/3.3, 4-3-4/7.1, 4-3-4/ 7.9 , 4-3-4/7.17, 4-3-4/ 7.19, 4-3-4/7.3.1 (d)

**National Standards:** UL File E117114, UL 1012; ANSI/IEEE C62.41, C37.90a

**International Standards:** CSA 22.2 No. 107.2; EN 60335-1, EN 60335-2-29; EN 61000-6-4 & EN 55022,Class A; IEC 61000-6-2, -4-2 to -4-6 & -4-11;

**Government Authority:**

**EUMED:**

**Others:**

Model Certificate	Model Certificate No	Issue Date	Expiry Date
PDA	13-HS1014518-1-PDA	03/MAY/2013	02/MAY/2018

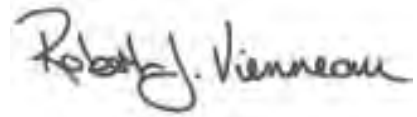

ABS Programs

ABS has used due diligence in the preparation of this certificate and it represents the information on the product in the ABS Records as of the date and time the certificate was printed. Type Approval requires Drawing Assessment, Prototype Testing and assessment of the manufacturer's quality assurance and quality control arrangements. Limited circumstances may allow only Prototype Testing to satisfy Type Approval. The approvals of Drawings and Products remain valid as long as the ABS Rule, to which they were assessed, remains valid. ABS cautions manufacturers to review and maintain compliance with all other specifications to which the product may have been assessed. Further, unless it is specifically indicated in the description of the product; Type Approval does not necessarily waive witnessed inspection or survey procedures (where otherwise required) for products to be used in a vessel, MODU or facility intended to be ABS classed or that is presently in class with ABS. Questions regarding the validity of ABS Rules or the need for supplemental testing or inspection of such products should, in all cases, be addressed to ABS.



## **SENS Limited Warranty - IQ Chargers**

### **What is covered?**

This warranty covers any defect in material and workmanship on IQ model battery chargers manufactured by Stored Energy Systems, a Colorado Limited Liability Company (SENS).

### **What this warranty does not cover:**

This warranty does not cover damages, defects or failures of your equipment resulting from shipping damage, accidents, installation errors, unauthorized adjustment or repair, unauthorized third-party service, failure to follow instructions, misuse, fire, flood, acts of persons not in our control, and acts of God.

### **For how long:**

Five (5) years from date of shipment.

### **What we will do:**

If your battery charger is defective within five years of date of shipment, we will repair it or, at our option, replace it at no charge to you.

If we choose to replace your charger, we may replace it with a new or refurbished one of the same or similar design. The repair or replacement will be warranted for the remainder of the original five-year warranty period. If we determine that your charger cannot be repaired or replaced, we will refund its purchase price to you.

### **What we ask you to do:**

Contact SENS service department to obtain warranty service instructions. To obtain warranty service the product must be returned, freight prepaid, to the factory under a Return Material Authorization (RMA) number provided SENS. If, in SENS' opinion, the problem can be rectified in the field, SENS may elect to ship replacement parts for customer installation instead of having the product returned to the factory.

### **Limitation:**

This warranty is limited to defects in material or workmanship of the product. It does not cover loss of time, inconvenience, property damage or any consequential damages. Repair, replacement or refund of the purchase price of the equipment is your exclusive remedy.