

PowerCore® TEC-10

Turnkey Electronic Controller

A superior turnkey electronic controller, the PowerCore® TEC-10 panel provides full control of your engine including auto start/stop, auto throttling and display of engine parameters along with critical faults from the engine/application. The TEC-10 supports SAE J1939 CAN protocols for electronically governed engines as well as analog sensors on mechanical engines for fault and safety warnings/shutdowns.

The TEC-10 follows a standard operating sequence of 22 machine states that happen in a predetermined order. These machine states may be set to zero if not needed or adjusted to fit the application. The incredibly versatile menu structure allows parameters and settings to be changed from the face without the need of a PC tool, if desired. This flexibility allows for the same controller panel to be used across many applications and provides the operator familiarity with the controller panel in a variety of uses.

The controller panel features molded connectors that utilize industry-standard Deutsch connectors and are compatible for use on the simplest mechanical engine to the most advanced, fully electronic Tier 4 engines.*

Specifications

TEC-10 Panel

Operating Voltage: 8-32 VDC, reverse battery polarity and load dump protected

Operating Temperature: -40° to +85° C (-40° to 185° F)

Storage Temperature: -40° to +85° C (-40° to 185° F)

Cranking Power Holdup: 0 VDC up to 50 mS (also good for brownout/blackout instances)

IP Rating: IP67

Total Current Consumption:

Power on in stopped state; 117 mA at 12 VDC. Power on in standby mode; 52 mA at 12 VDC.

Mating Connectors:

21 Position, Deutsch HDP26-24-21SE,

31 Position, Deutsch HDP26-24-31SE

Communications:

(1) CAN: J1939

(1) RS485: Modbus RTU



Designed as a plug-and-play solution, the TEC-10 can also utilize a free PC configuration tool that allows customers to change default settings as well as provide three levels of passcode protection, if needed.

The rugged TEC-10 panel can be mounted directly to the engine or engine/application cover. Built to endure industrial environments from full sun to wide temperature ranges, the panel features a high degree of sealing for dust and water as well as the ability to withstand higher vibration with exposure.

*Murphy Industrial Harness or John Deere OEM engine harnessing required.

Outputs (8):

(3) Relays:

(2) +DC (10A)

(1) Form C (10A)

(2) Low-side FET: -DC (1A)

(2) High-side FET: +DC (1A)

(1) Dedicated Alternator Excitation +DC (1A)

Inputs (9):

(5) Digital, configurable (active on High, Low, Open)

(3) Analog, configurable (4-20 mA, 0-5V, resistive or digital ground)

(1) Frequency, supporting:

Magnetic pickup (30 Hz - 10 kHz, 2.0 VAC-120 VAC) and

Engine Alternator (30 Hz - 10 kHz, 4.5 VRMS - 90 VRMS)

Languages: English, Spanish, German, French, Italian

Dimensions: 9.59 x 7.34 x 5.20 in. (243.48 x 186.5 x 132.23mm) (WxHxD)

Enclosure: Polycarbonate

How to Order

Part Number	Model and Description	Notes
40700495	PowerCore TEC-10 Panel	
40000602	Engine Harness, 21 Position Connector 10' Whip Harness (3m approx.)	
40000603	I/O Harness, 31 Position Connector 10' Whip Harness (3m approx.)	
40000479	Deutsch Connector Kit, 21-pin & 31-pin, Panel Connector Kit	
40000531	Deutsch Connector kit, 21-pin, Panel Connector Kit, Engine Only	
78700046	Deutsch Connector kit, 31-pin, Panel Connector Kit, I/O Only	

Product and Mounting Dimensions

PowerCore TEC-10

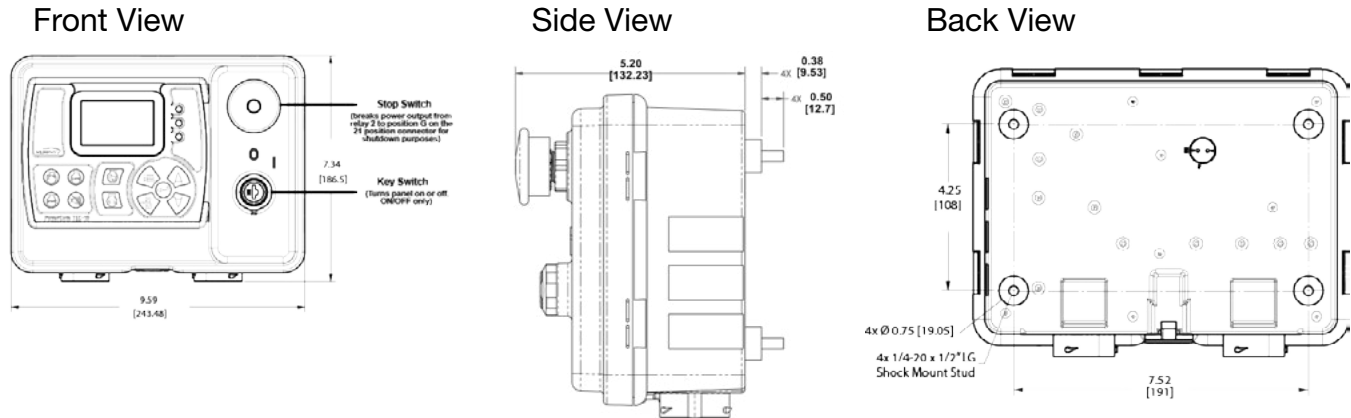

Connectors

Deutsch 21 pin Connector Engine		Deutsch 31 pin Connector I/O	
PIN	Function	PIN	Function
A	Unavailable	1	Unavailable
B	Battery (positive)	2	Unavailable
C	Unavailable	3	Unavailable
D	Relay 1, +DC (10A), Default Setting: Crank	4	Unavailable
E	Battery (negative)	5	Unavailable
F	J1939 CAN Shield	6	Unavailable
G	Relay 2, +DC (10A), Default Setting: ECU Enable	7	Unavailable
H	Unavailable	8	Unavailable
J	Alternator Excite Output, +DC (1A)	9	Analog Input 3, Default Setting: Not Used
K	Unavailable	10	Unavailable
L	Unavailable	11	Unavailable
M	Unavailable	12	Unavailable
N	Unavailable	13	Digital Output 1, +DC, (1A), Default Setting: Not In Auto
P	Unavailable	14	Digital Input 3, Default Setting: Dual Contact Stop, B-
R	Digital Output 3, -DC, (1A), Default Setting: Throttle Decrease	15	Unavailable
S	Digital Output 4, -DC, (1A), Default Setting: Throttle Increase	16	Unavailable
T	Frequency Input	17	Relay 3 Common (RLY 3 Defaulted to Not Used) 10A Max
U	J1939 CAN Low (includes terminating resistor, Default to ON)	18	Relay 3 NC (RLY 3 Defaulted to Not Used) 10A Max
V	J1939 CAN High (includes terminating resistor, Default to ON)	19	Relay 3 NO (RLY 3 Defaulted to Not Used) 10A Max
W	Analog Input 2, Default Setting: Not Used	20	Digital Input 5, Default Setting: Low Lube Oil Level B-
X	Analog Input 1, Default Setting: Not Used	21	Digital Input 1, Default Setting: Not Used
		22	Unavailable
		23	Digital Input 2, Default Setting: Dual Contact Start, B-
		24	Digital Output 2, +DC, (1A) Default Setting: Engine Running
		25	Unavailable
		26	Unavailable
		27	Unavailable
		28	Unavailable
		29	Digital Input 4, Default Setting: Low Coolant Level, B-
		30	RS485 (positive)
		31	RS485 (negative)