

TABULATION BLOCK			
PART NO.	DRIVE SIZE	"T" THREAD SIZE	TANG P/N
023-004-A	0.104" SQUARE	7/8-18	760-260
023-004-B	0.150" SQUARE	7/8-18	760-261
023-004-C	0.187" SQUARE	7/8-18	760-262
023-004-D	0.152" ROUND	7/8-18	760-263
023-004-E	0.187" ROUND	7/8-18	760-264
023-004-F	0.203" ROUND	7/8-18	760-265
023-004-G	DIN	22mm X 1.5	-
023-004-H	0.187" ROUND	22mm X 1.5	760-264

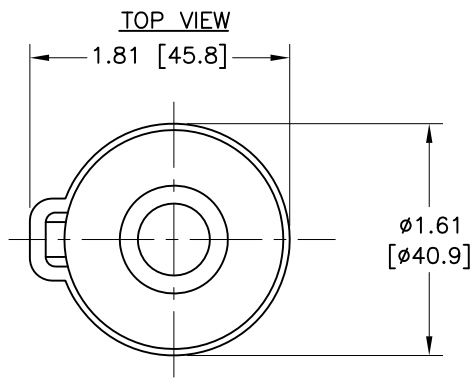

10" [254mm] LONG
8" [203mm] LONG

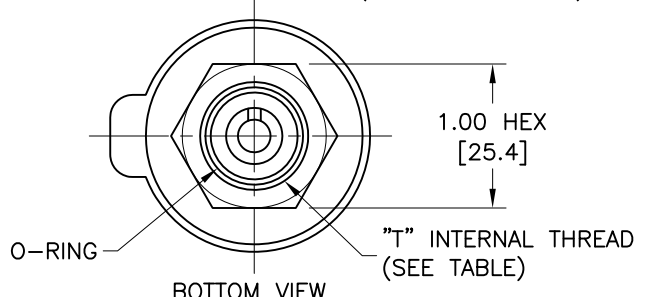
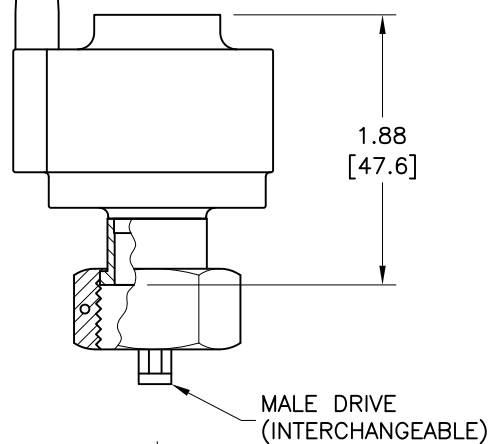
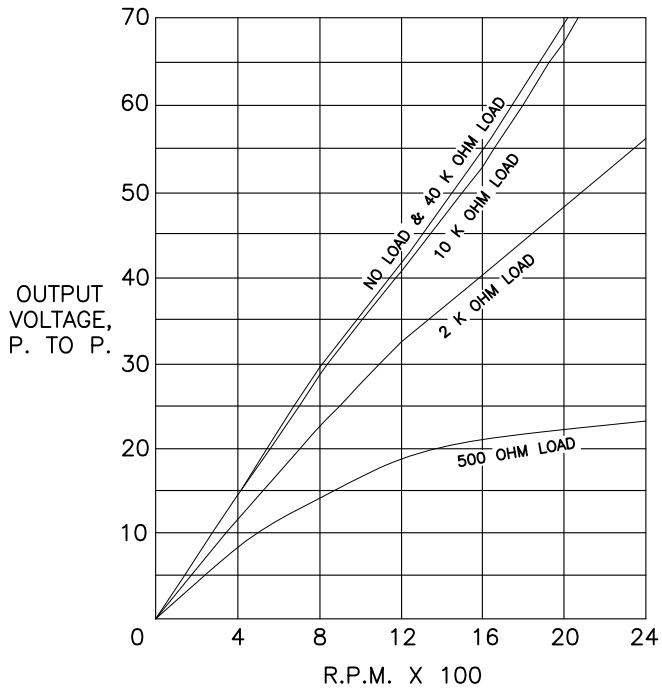

SPECIFICATIONS:

1. FREQUENCY: 8 PULSES PER REV.
2. DC SOURCE IMPEDANCE: 285 ±10 OHMS
3. INDUCTANCE: 107 mH @ 1000 Hz.
4. HOUSING MATERIAL: GLASS-FILLED NYLON
5. BEARING: DOUBLE-OILITE
6. LEAD WIRES: 18 AWG., 16/19 STRAND.

NOTES:

1. DUAL OUTPUT GENERATOR ALSO AVAILABLE.
2. SPECIAL LENGTHS AND CONNECTORS AVAILABLE.
3. AVAILABLE IN DIN, M22 X 1.5 METRIC THREAD.

This document involves CONFIDENTIAL proprietary design rights of HEWITT IND. and all designs, manufacturing, reproduction, use and sale rights regarding same are expressly reserved. It is submitted under a confidential relationship and the recipient agrees to assume custody and control thereof and that proprietary information contained herein shall not be reproduced or transferred to other documents or disclosed to others or used for manufacturing or any other purpose without prior written permission of HEWITT IND.

REVISIONS					TOLERANCES		HEWITT INDUSTRIES OF LOS ANGELES	
REV.	DESCRIPTION	EO#	DATE	BY	UNLESS OTHERWISE SPECIFIED:		TITLE:	
					DIMENSIONS ARE IN INCHES, METRIC EQUIVALENTS ARE IN [BRACKETS]:		SIGNAL GENERATOR	
					.X = .030 [0.76]		DRAWN BY: JAG	
					.XX = .010 [0.25]		PART NO. 023-004-X	
					.XXX = .005 [0.13]		APPR. BY: JH	
					FRACTIONS = 1/32		DATE: 08/29/11	
					ANGLES = ±1°		SHEET 1 OF 1	
					SCALE: 3/4			

A